

DEMA Pro-Fill II Sink Dispenser

MODELS PF652GAP, PF652AG, PF652GAP-2M, & PF652AG-2M

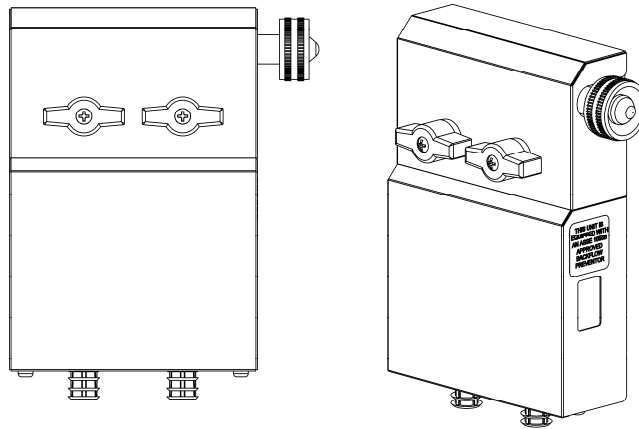

Overview

The PRO-FILL II Sink Dispenser mixes water with cleaning chemicals and dispenses these solutions. This unit is typically used to fill three-compartment sinks. The dispensers are equipped with ASSE 1055B Approved backflow devices.

The “2M” models are equipped with two water inlet hookup connectors. This allows the dispenser to dispense water from 2 different water sources. Typical uses of this system are to use hot water and cold water independently.

Each dispenser can be set up to meet specific application needs with the ability to offer:

- High flow dispensing of 2 products
- Chemical dilution ratios up to 7:1
- Supplied metering tips allow for preset dilution ratios
- 4 gallon per minute dispensing

Warnings









All installations must conform to local plumbing codes and use approved backflow prevention devices. A pressure indicating tee is to be installed with existing faucets according to local plumbing codes in the state of Wisconsin and any other state that requires the use of a pressure indicating tee.



ALWAYS WEAR PROTECTIVE CLOTHING AND EYEWEAR WHEN WORKING WITH CHEMICAL PRODUCTS.

Packing List

Part Number	Description	PF652GAP	PF652AG	PF652GAP-2M	PF652 AG-2M	
L806	CHEMICAL LABELS	1	1	1	1	
100-15K	METERING TIP KIT	1	1	1	1	
61-107-2	SMALL CERAMIC WEIGHT	2	2	2	2	
100-16E-1	TUBING & FOOT VALVE 1/4" X 8'	2	2	2	2	
61-21	OUTLET TUBE 1/2" X 6'	1		1		
63-83	OUTLET TUBE 9/16" X 6'		1		1	
66-53-4	MOUNTING SCREW	4	4	4	4	
66-52	WALL ANCHOR	4	4	4	4	

Operational Requirements

Water Supply Requirements

	Minimum	Maximum
Water Pressure	20 psi (1.38 bar)	125 psi (8.62 bar)
Water Temperature	-	*150°F (65.5°C)

*Caution: 150°F (65.5°C) is “hot” to the touch and must be handled with care.

Overall Size

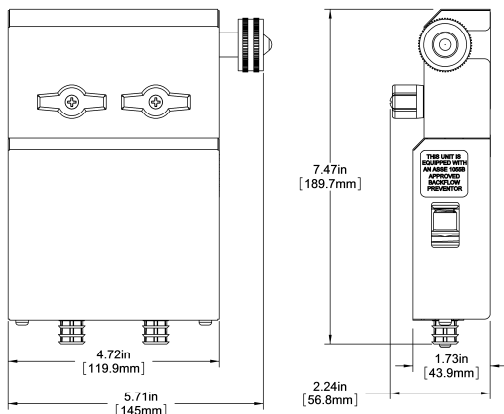

Typical Install

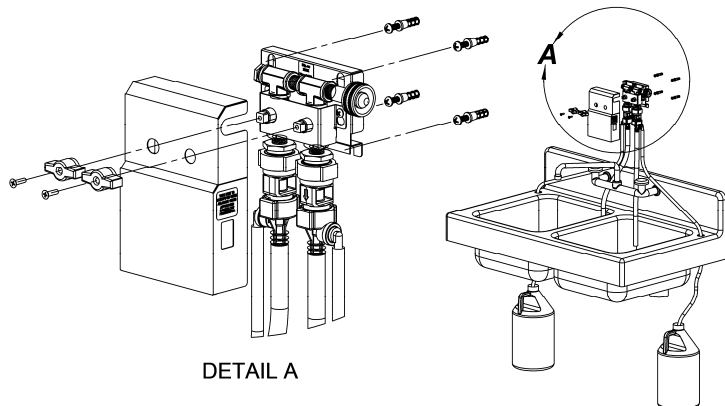

Installation

Mounting Dispenser Assembly

1. Remove the ball valve screws and knobs then slide the cover off of the valve assembly.
2. Position the dispenser on the wall and mark the four mounting screw locations.
3. Install the supplied anchors in the wall and install the screws half way into the anchors.
4. Slide the dispenser over the screw heads and tighten down the screws.
5. Install the desired metering tips in both elbows as shown.
6. Cut the chemical supply tubes to length by removing excess tubing. Install the supplied ceramic weights onto the tubes then install the tubes onto the elbow barbs. Place the tube ends with the ceramic weight and foot valve into the proper chemical containers. Note: Chemical containers can be no greater than 6' (1.83 meters) below the dispenser.
7. Cut outlet tubing to desired length and install to proportioner barbs. Properly place tubing in sink where chemical is desired.
8. Replace the cover, ball valve knobs, and tighten the screws.

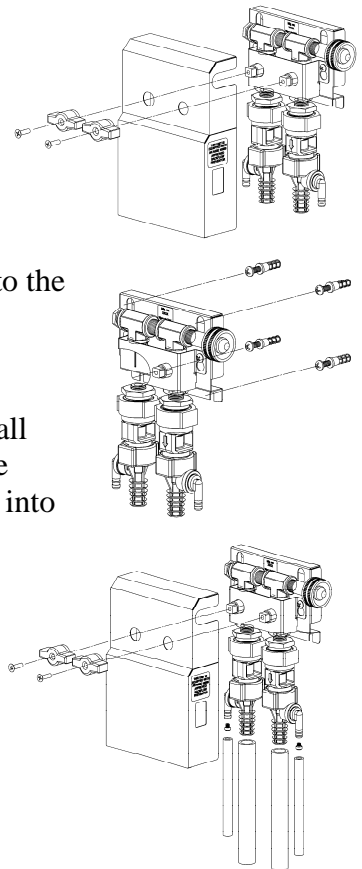

Water Supply

(Inlet pressure must be between 20 psi (1.38 bar) and 125 psi (8.62 bar)).

1. Attach a garden hose to the water inlet on the unit.

Table 1: “Air Gap” & “Action Gap” Induction Flow Rates w/Standard 1/4" Barb and Tubing

Metering Tip Color	163 BAG (4 GPM Flow Rate Air Gap Proportioner)						(4 GPM Flow Rate Action Gap Proportioner)					
	Injection Rates For Viscosities Shown											
	1 cps		75 cps		200 cps		1 cps		75 cps		200 cps	
	Oz/Gal	Ratio	Oz/Gal	Ratio	Oz/Gal	Ratio	Oz/Gal	Ratio	Oz/Gal	Ratio	Oz/Gal	Ratio
Tan	0.30	427-1	0.20	640-1	0.15	853-1	0.33	387-1	0.26	500-1	0.12	1090-1
Orange	0.40	320-1	0.30	427-1	0.25	512-1	0.42	307-1	0.32	430-1	0.17	735-1
Turquoise	0.60	213-1	0.40	320-1	0.30	427-1	0.51	251-1	0.34	382-1	0.19	676-1
Pink	0.80	160-1	0.50	256-1	0.40	320-1	0.78	165-1	0.56	230-1	0.3	422-1
Light Blue*	1.00	128-1	0.70	183-1	0.45	284-1	0.87	147-1	0.67	192-1	0.33	391-1
Brown	1.20	107-1	0.80	160-1	0.50	256-1	0.99	129-1	0.74	174-1	0.37	345-1
Red	1.50	85-1	0.90	142-1	0.60	213-1	1.37	93-1	0.91	141-1	0.44	289-1
White	1.85	69-1	1.10	116-1	0.70	183-1	1.52	84-1	1.04	123-1	0.48	264-1
Green	2.00	64-1	1.25	102-1	0.80	160-1	1.72	74-1	1.22	105-1	0.52	244-1
Blue	2.50	51-1	1.50	85-1	0.82	156-1	2.13	60-1	1.27	101-1	0.54	239-1
Yellow	4.00	32-1	1.85	69-1	0.90	142-1	3.05	42-1	1.71	75-1	0.56	229-1
Black	5.50	23-1	2.00	64-1	0.94	136-1	4.50	28-1	1.96	65-1	0.57	224-1
Purple	8.80	15-1	2.40	53-1	0.96	133-1	7.75	17-1	2.4	53-1	0.59	217-1
Gray	11.65	11-1	2.50	51-1	1.00	128-1	9.86	13-1	2.54	50-1	0.63	204-1
No Tip	16.20	8-1	3.00	43-1	1.20	107-1	19.63	7-1	3.16	40-1	0.67	190-1

*Metering tip color was formerly clear.

Notes: All induction flow rates are based on a water pressure of 40 psi.

(1 cps (centipoises)-viscosity of water, 75 cps-viscosity of light weight detergents, 200 cps-viscosity of most dishwasher detergents)

Leaner dilutions can be achieved by ordering DEMA ultra lean metering tip kit 100-15KU.

Ratios as low as 100 parts-per-million can be achieved with the use of a DEMA capillary metering tip. Contact DEMA customer service for more information.

If you are having difficulty achieving the ratio you require, call DEMA and ask for the technical service department.

Operation

The operation of this unit is simple. Once all the correct tubing is in place, simply rotate the correct ball valve knob to the “on” position and let the chemical/water solution fill the sink to the desired level. Now rotate the ball valve fully into the “off” position.

Troubleshooting

Symptom	Probable Cause	Remedy
Proportioner fails to draw chemical properly.	<ol style="list-style-type: none"> 1. Insufficient water supply pressure. 2. Foot valve has dirt/chemical build-up. 3. Proportioner metering tip clogged with dried chemical. 4. Mineral deposits are located on Air Gap nozzle. 5. Valve not rotated in fully open position. 	<ol style="list-style-type: none"> 1. 20 PSI is the minimum allowable pressure. Seek Plumber if necessary to increase water pressure. 2. Soak in hot water to clean. 3. Soak in hot water to clean interior passages. 4. Soak nozzle and inlet screen in hot water or product such as CLR to clean mineral deposits. 5. Always turn knob in fully opened positions.
“Air Gap” Proportioner is dripping or spraying a mist (fan pattern) of water.	<ol style="list-style-type: none"> 1. Mineral deposits are located on Air Gap nozzle. 	<ol style="list-style-type: none"> 1. Soak nozzle and inlet screen in hot water or product such as CLR to clean mineral deposits.
Water valve is not shutting off completely.	<ol style="list-style-type: none"> 1. Ball valve not closed. 2. Ball valve has internal leakage. 	<ol style="list-style-type: none"> 1. Always turn knob clockwise to fully closed position. 2. Replace ball valve
Threaded connections are leaking water.	<ol style="list-style-type: none"> 1. The connection between the sink dispenser and water supply line is too loose or rubber washer is missing. 2. Backflow prevention devices and/or proportioners are too loose. 	<ol style="list-style-type: none"> 1. Shut water supply off first. Carefully tighten the female hose coupling on the sink dispenser to the inlet water supply line. Do not overtighten. 2. Tighten loose connection(s) with tools if necessary. Do not overtighten if using tools.
Proportioner continues to draw chemical after water valve is closed.	<ol style="list-style-type: none"> 1. Concentrated chemical is positioned higher than the proportioner. 	<ol style="list-style-type: none"> 1. Move the concentrated chemical so it is lower than the proportioner.

Parts List (See pages 4-5)

COVER, MOUNTING BRACKETS, AND HARDWARE		
NO.	PART NO.	DESCRIPTION
1	65-35-1	Cover, Dual Valve (Stainless Steel)
2	65-34-1	Bracket, Valve Retaining (Stainless Steel)
3	60-67-1	#8 X 1/2” Lg. Screw (Type B)
4	65-33-1	Bracket, Wall Mounting (Stainless Steel)
5*	L806	Chemical Labels
6*	L1129	Upper on/off Pro-Fill Label
7*	L1166	Lower Pro-Fill Unit Label

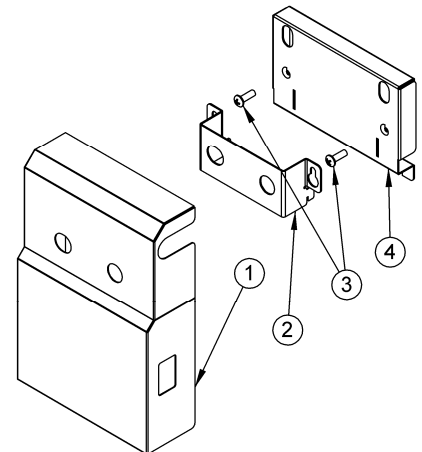

*Items not Shown

PF652GAP & PF652AG DUAL BALL VALVE ASSEMBLY		
NO.	PART NO.	DESCRIPTION
1	65-6	¼" NPT Plug
2	65-30-1	¼" NPT Tee
3	25-137-6U	¼" NPT Nipple
4	65-10	Garden Hose Coupling
5	65-17-2	Hose Adapter Stem
6	100-38	Strainer Washer
7	65-7	¼" NPT Ball Valve with Knob
8	65-31-3U	Adapter, Garden Hose X ¼" NPT (brass)
9	65-11	Swivel Adapter Kit
10	65-2K	Knob
11	81-19-20	Knob Screw

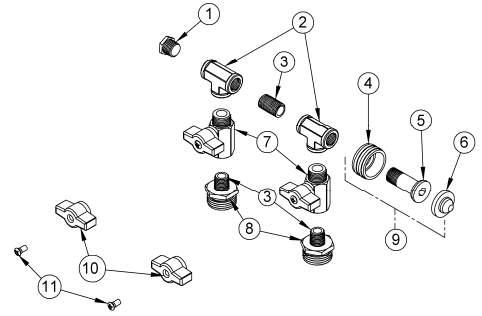

PF652GAP-2M & PF652AG-2M DUAL BALL VALVE ASSEMBLY		
NO.	PART NO.	DESCRIPTION
1	61-121	¼" Street Elbow
2	25-137-12U	¼" NPT Nipple
3	65-30-1	¼" NPT Tee
4	65-20-1	¼" Spacer Plug (Solid)
5	65-7	¼" NPT Ball Valve with Knob
6	65-31-3U	Adapter, Garden Hose X ¼" NPT (brass)
7	25-51-12	¼" NPT X 3/8" O.D. Tube Compression Fitting
8	65-2K	Knob
9	81-19-20	Knob Screw
10	25-137-6U	¼" NPT Nipple

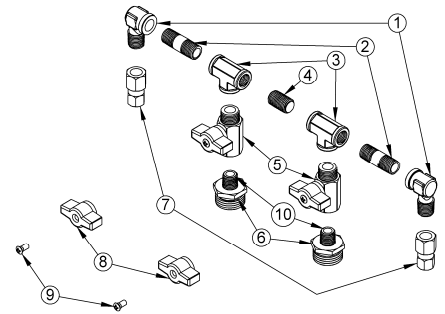

BACK FLOW/PROPORTIONING DEVICES, TIPS, & TUBING		
NO.	PART NO.	DESCRIPTION
1	16-30	ACTION GAP Assembly
2	61-22-3	Proportioner Assembly (4 GPM) w/Elbow
3	61-22-3BAG-EL2	AIR GAP Proportioner Ass'y (4 GPM) w/Elbow
4	100-15K	Mitering Tip Kit (14 Sizes)
5	100-12	¼" I.D. X 8' Lg. Vinyl Tubing
6	61-107-2	Ceramic Weight (3/8" I.D.)
7	100-16E	Foot Valve Assembly (EPDM) – Std. Equipment
	100-16S	Foot Valve Assembly (Silicone) - Available
	100-16V	Foot Valve Assembly (Viton) - Available
8	61-21	½" I.D. X 6' Lg. Vinyl Tubing
9	63-83	9/16" I.D. X 6' Lg. Vinyl Tubing

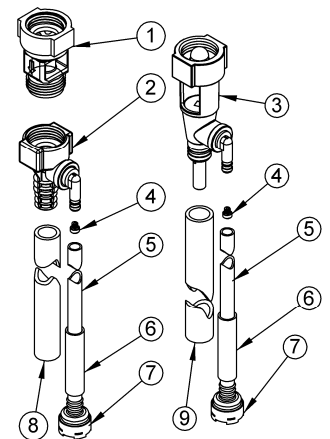

Warranty

Merchandise Returns

No Merchandise will be Returned for Credit Without DEMA'S Written Permission. Returned Merchandise Authorization Number is Required in Advance of Return.

Product Warranty

DEMA products are warranted against defective material and workmanship under normal use and service for one year from the date of manufacture. This limited warranty does not apply to any products that have a normal life shorter than one year or failure and damage caused by chemicals, corrosion, physical abuse, or misapplication. Rubber and synthetic rubber parts such as "o"-rings, diaphragms, PVC tubing, and gaskets are considered expendable and are not covered under warranty. This warranty is extended only to the original buyer of DEMA products. If products are altered or repaired without prior approval of DEMA, this warranty is void.

Defective units or parts should be returned to the factory with transportation prepaid. If inspection shows them to be defective, they will be repaired or replaced without charge, F.O.B. factory. DEMA assumes no liability for damages. Return merchandise authorization number must be granted in advance of returned units for repair or replacement (See "Merchandise Returns" above).