

# DEMA STU-II (Signal Transfer Unit) Unit Instructions

Read this instruction sheet completely before attempting to install this device. All installations must be in accordance with city, county, state or provincial electrical codes and should be performed by a certified electrician. The use of a licensed electrical contractor for installation is recommended.

This unit is designed as the STU (Signal Transfer Unit) module used with DEMA models 842, 844, 845, and 846. The STU communicates with the control board housed in the DEMA laundry dispenser case. The signals are provided by means of an RJ-45 patch cable assembly. This cable plugs into the RJ-45 connectors found on the STU and control board. The cables should be packed with the various components of a full DEMA Laundry dispenser.

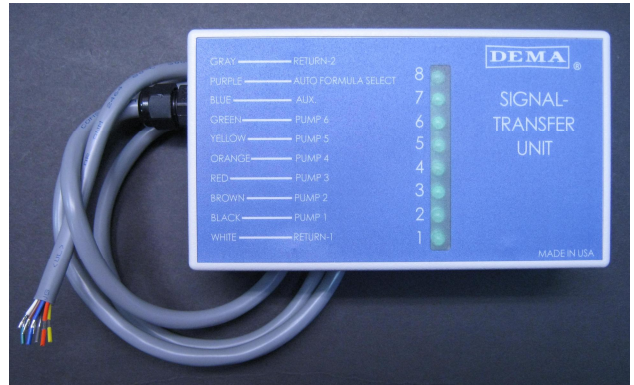

The wiring of the DEMA STU-II is shown on the front label. The supply signals from the laundry machine can be 12VAC-250VAC. There are 2 common wires (white and gray). The out of the box product from DEMA can use either one or both commons. It is not necessary to wire both commons. However, both commons can be wired to the machine common or return. All trigger wires and commons are in a jacketed cable assembly.

## Voltage Cutout Switches

It is possible to cutout supply signals from the machine that fall below 70VAC.

**Caution:** Before this can be done, it is critical to assure that the laundry machine has been powered down at the electrical service panel. There is a potential for exposure to high voltage conditions when the Signal Transfer Unit enclosure is opened. All power to the laundry machine must be turned off.

When the STU-II enclosure is opened the voltage cutout switches can be accessed. Both switches should be set to the same setting when commons are not split.

- When these switches are set to the 12V-100V setting the system can accept supply signals from the machine that range from 12-250VAC. **This is the factory default setting for any product.**
- When these switches are set to 100V-240V, the system can accept signals that range from approximately 70-250VAC.
- It is important to make sure these two switches are set to the same position unless the commons have been split. For more information on this, please see below.

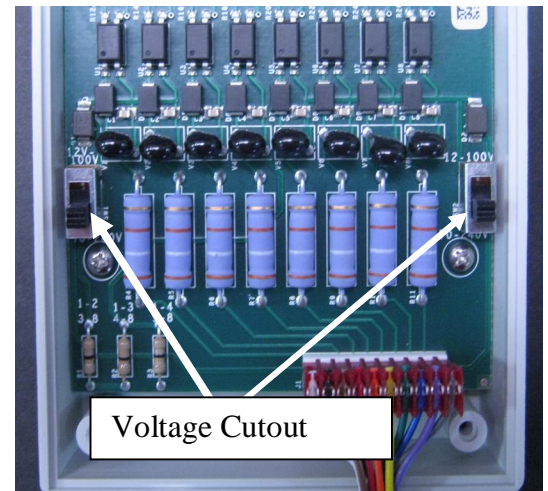

**Note:** When combining 2 or more trigger signal inputs from one supply signal from the laundry machine, it is recommended to have the voltage cutout switches set to 12V-100V settings. The system will accept 12-250VAC trigger signals.

## Splitting Commons

The STU-II has the ability to have the two commons split so that one common wire will work with a range of trigger inputs while the other common wire will work with the remaining trigger inputs.

**Caution:** Before the commons are split, it is critical to assure that the laundry machine has been powered down at the electrical service panel. All power to the laundry machine must be turned off.

When the STU-II enclosure is opened the common wire can be split to one of four configurations. The four choices are:

No Split (factory default)	1-2 and 3-8
1-3 and 4-8	1-4 and 5-8

**It should be noted that once the commons are split, they cannot be modified again.** Using a pair of small wire clips snip the resistor that provides the split that is desired.

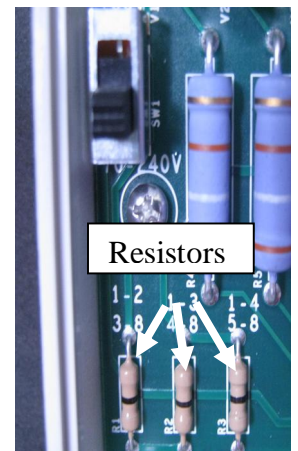

# DEMA STU-II (Signal Transfer Unit) Unit Instructions

Common Configurations		
Resistor Selection	White (Return 1)	Grey (Return 2)
1-2, 3-8	1, 2	3, 4, 5, 6, 7, 8
1-3, 4-8	1, 2, 3	4, 5, 6, 7, 8
1-4, 5-8	1, 2, 3, 4	5, 6, 7, 8

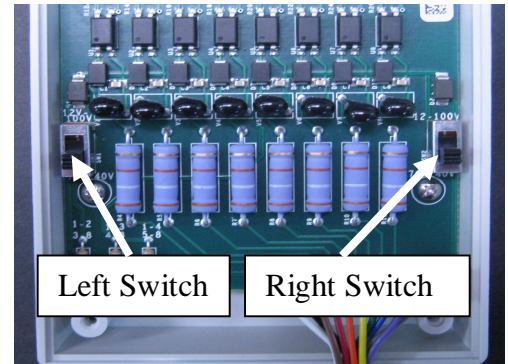

When the commons are split the voltage cutout switches will be assigned as follows.

- Left Switch will go with triggers assigned to the white common (Return 1).
- Right Switch will go with triggers assigned to the grey common (Return 2)
- It is possible to have each switch to individual settings.

## Wiring Configurations

STU Wiring Configuration (For Sequence Mode) (For Formula Select Mode or Relay Mode)				
Trigger Input	Line (signal)	Common	Function of Trigger Input	
			Sequence Mode	Formula Select/Relay Mode
1	Black	White or Grey	Event Trigger	Signal Pump 1
2	Brown	White or Grey	Event Trigger	Signal Pump 2
3	Red	White or Grey	Reset (opt'l) ex. door switch	Signal Pump 3
4	Orange	White or Grey	Not Used	Signal Pump 4
5	Yellow	White or Grey		Signal Pump 5
6	Green	White or Grey		Signal Pump 6
7	Blue	White or Grey		Signal Flush (opt'l)
8	Purple	White or Grey	Auto Formula Select (see AFS note)	

## Auto Formula Select

This allows the formulas to be selected based on a trigger signal that is received from the laundry machine. The following list outlines the setup of this feature: The 8<sup>th</sup> trigger input on the STU is used for this purpose. A trigger source that can be programmed at the laundry machine will be required. The timing of this trigger source is what determines which formula is selected by the IQ-80. To determine the amount of signal time for any formula simply calculate as follows:

- Multiply the formula number by 2 then subtract 1
- Example: Formula 7 needs a trigger signal equal to 13 seconds. ( $7 \times 2 = 14$  then  $14 - 1 = 13$ ). A 13 second trigger signal to STU input number 8 (purple and purple striped wires) will change the Atlas to formula 7.

Note: The amount of formulas available is based on the laundry system product.

- 844, 845, 846 Series or 84.65.1E Conversion Kit is 9 formulas maximum. All of these product lines use software V2.56 or V3.2x.
- 844E, 845E, 846E Series or 84.65.1E Conversion Kit is 30 formulas maximum. All of these product lines use software V4.x
- 844P (Atlas) Series is 30 Formulas maximum.

## Auxiliary Wire (Blue)

The blue auxiliary wire is used to signal the 7<sup>th</sup> pump for a system when a flush mode is turned off.

## Return Policy

No merchandise may be returned for credit without DEMA Engineering Company's written permission. Return Merchandise Authorization (RMA) number required in advance of return.

## Warranty

DEMA products are warranted against defective material and workmanship under normal use and service for one year from the date of manufacture. This limited warranty does not apply to any products, which have a normal life shorter than one year or failure and damage caused by chemicals, corrosion, improper voltage supply, physical abuse or misapplication. Rubber and synthetic rubber parts such as "O"-rings, diaphragms, squeeze tubing and gaskets are considered expendable and are not covered under warranty. This warranty is extended only to the original buyer of DEMA products. If products are altered or repaired without prior approval of DEMA, this warranty will be void.

Defective units or parts should be returned to the factory with transportation prepaid. If inspection shows them to be defective, they will be repaired or replaced without charge. F.O.B. factory DEMA assumes no liability for damages. Return merchandise authorization number to return units for repair or replacement must be granted in advance of return.