

DEMA MODEL P603 & P603T SELECT-O-MATIC

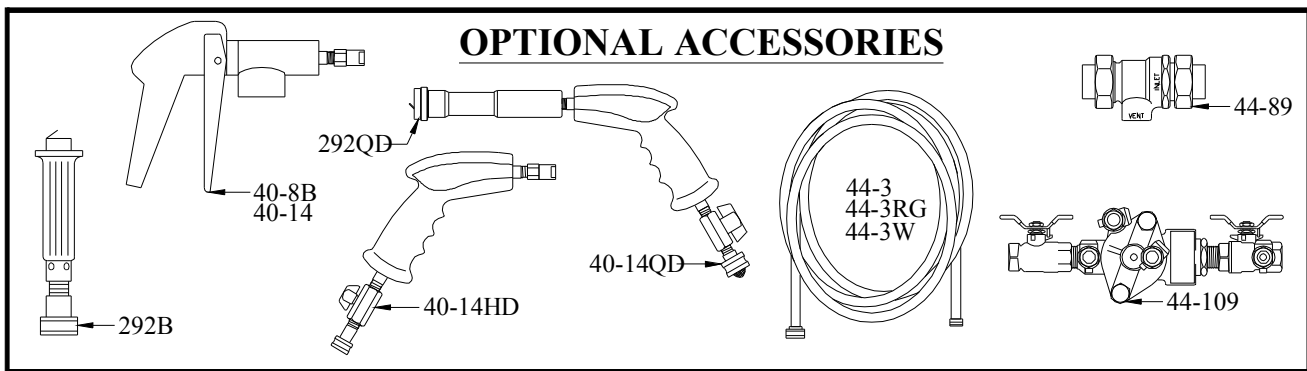
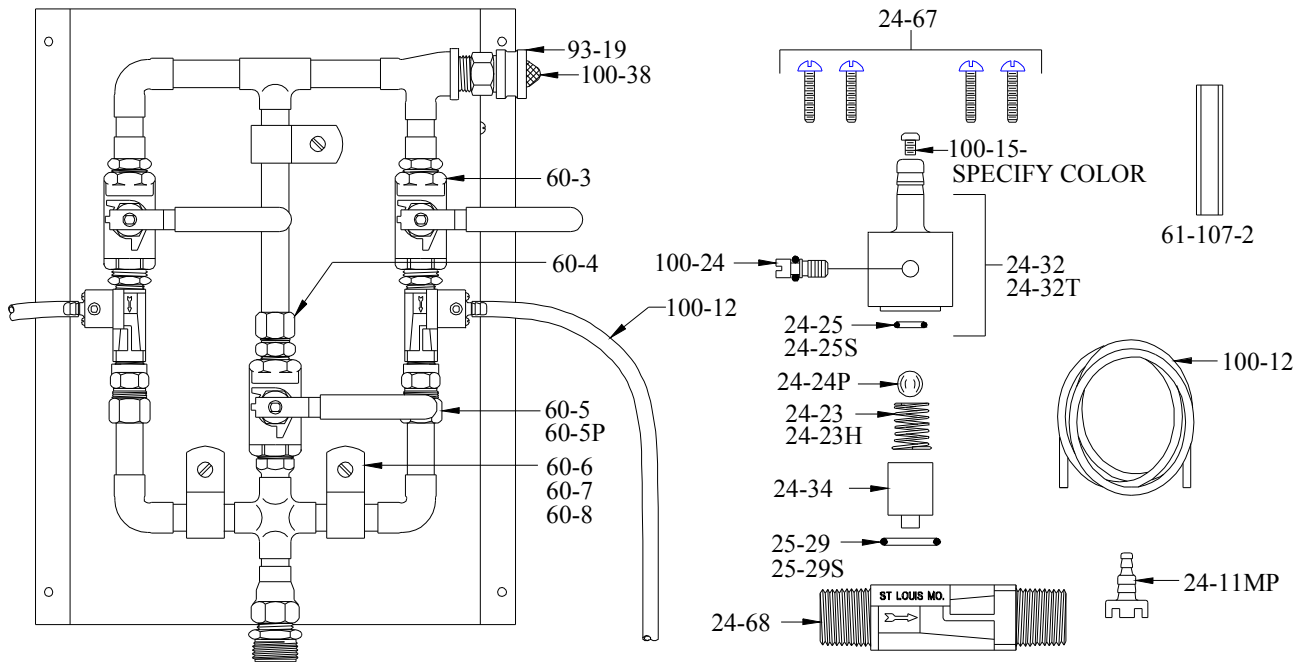

PART NO.	DESCRIPTION
24-11MP	FOOT STRAINER
24-23	CHECK VALVE SPRING
24-23H	CHECK VALVE SPRING (P603TC ONLY)
24-24P	CHECK VALVE BALL
24-25	CHECK VALVE O-RING
24-25S	CHECK VALVE O-RING (P603TC ONLY)
24-32	METERING KNOB
24-32T	METERING KNOB
24-34	CHECK VALVE CORE
24-67	SCREW (1" LG-4 REQD.)
24-68	INJECTOR BODY
25-29	METERING KNOB O-RING
25-29S	METERING KNOB O-RING (P603TC ONLY)
60-3	BALL VALVE
60-4	COMPRESSION FITTING
60-5	COMPRESSION FITTING
60-5P	COMPRESSION FITTING
60-6	SCREW
60-7	NUT

PART NO.	DESCRIPTION
60-8	MOUNTING BRACKET
61-107-2	CERAMIC WEIGHT
93-19	ADAPTOR
100-12	VINYL TUBING 1/4ID X 8'LG
100-15-	METERING TIP SPECIFY COLOR
100-24	METERING SCREW
100-38	STRAINER WASHER
OPTIONAL ACCESSORIES	
44-3	HOSE (BLACK) 25' X 1/2 ID
44-3RG	HOSE (RED) SPRING GARD 25' X 1/2 ID
44-3W	HOSE (WHITE) 25' X 1/2 ID
40-8B	SPRAY GUN
40-14	SPRAY GUN
40-14HD	HEAVY DUTY SPRAY GUN
40-14QD	HEAVY DUTY SPRAY GUN W/ DISC.
44-89	BACKFLOW PREVENTER(A.S.S.E. 1012)
44-109	BACKFLOW PREVENTER(A.S.S.E. 1013)
292B	FOAM WAND
292QD	FOAM WAND W/ DISCONNECT