

# DEMA DATA GRIP

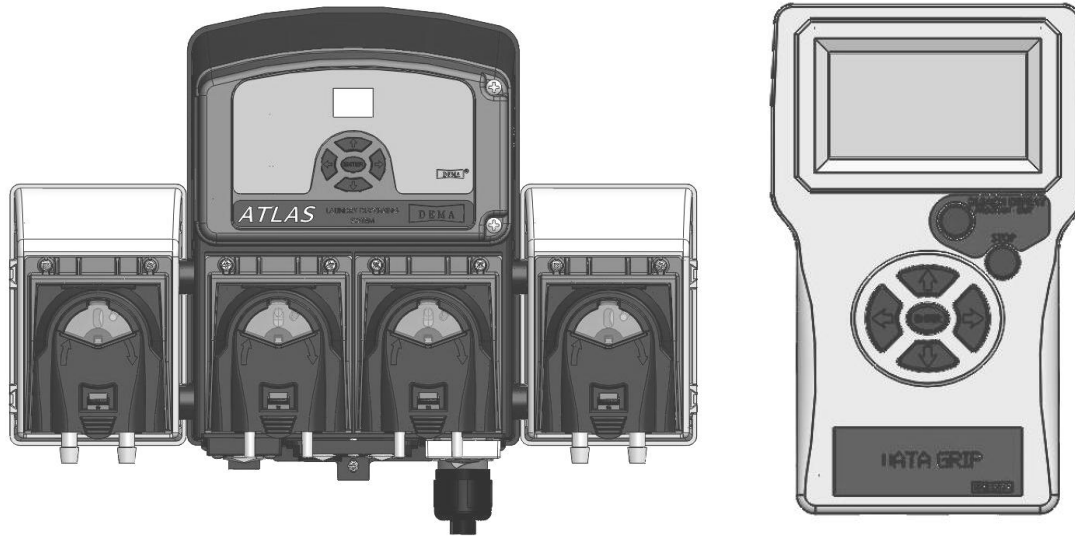

## Overview

---

The Data Grip is a data management system intended to integrate with the Atlas Laundry System to provide data management of the chemicals used, cycles ran, product cost and produce invoicing. The Data Grip is designed to use the Signal Transfer Unit and IQ-85 Control board in order to maintain quality data and convert it to usable reports.

## Warnings

---



Installation of DEMA products must meet all applicable electrical codes and regulations established by national, city, county, parish, provincial or other agencies. It is possible that electrical codes and regulations require that a certified electrical contractor or engineer perform the electrical installation. For questions, contact a certified electrician.



**ALL ELECTRICAL POWER MUST BE TURNED OFF TO THE DISPENSER AND TO THE APPLIED MACHINE.**



All installations must conform to local plumbing codes and use approved backflow prevention devices. A pressure indicating tee is to be installed with existing faucets according to local plumbing codes in the state of Wisconsin and any other state that requires the use of a pressure indicating tee.



**ALWAYS WEAR PROTECTIVE CLOTHING AND EYEWEAR WHEN WORKING WITH CHEMICAL PRODUCTS.**

# Table of Contents

<b>Specifications .....</b>	<b>3</b>
<b>Installation.....</b>	<b>4</b>
<b>Operation, How to Program the Unit .....</b>	<b>6</b>
<b>Navigating the Main Menu .....</b>	<b>6</b>
<b>Navigating the Setup Menu.....</b>	<b>7</b>
Clear Load Counts, Pump Volume.....	7
Formula Lockout, Set Sequence .....	8
Set Units, Test Formulas.....	9
<b>Navigating the Configure Menu .....</b>	<b>10</b>
Set Level Mode, Set Operate Mode, Set Flush Mode .....	10
Load Count Select, Bleach Defeat Select, Default Formula.....	11
Enter Program Names.....	12
<b>Navigating the Utility Menu.....</b>	<b>12</b>
Send Program File, Caputre Program File.....	12
Set Access Code, Formula Names, Product Names .....	13
Factory Default, Clear all Programs .....	14
<b>How to Prime the Pump.....</b>	<b>14</b>
<b>How to Use the Calibrate Feature .....</b>	<b>14</b>
<b>Setting Up the Data Management.....</b>	<b>15</b>
How to Set the Date and Time .....	15
Inputting the Account Information.....	16
Inputting the Machine Information .....	17
Inputting the Cost Information.....	18
Monetary Units, Volume Units .....	18
Shift Information, Product Cost, Price .....	19
Setting Invoice Pricing.....	20
Setting Up the Report to Be Run.....	21
Type .....	21
Period.....	22
Clear All Data.....	23
Run Report .....	24
<b>Navigating the Maintenance Menu.....</b>	<b>24</b>
Software Update.....	24
Copying Information to Another Data-Grip and Dispenser .....	25
<b>Trouble Shooting.....</b>	<b>28</b>
<b>Return Policy and Warranty .....</b>	<b>28</b>

# Specifications

## Packing List

	PART NO.	NOMENCLATURE	QTY.
A.	84-65-39DG	DATA GRIP Control Kit	1
B.	84-27-4	6 Foot RJ-45 Patch Cable	1

## Operational Requirements

The STU (Signal Transfer Unit) must be connected between the IQ-85 (844P) board and the laundry machine.

The Data Grip can be connected to the IQ-85 board or to the STU board with an RJ-45 Patch Cable.

The Data Grip will be powered through the RJ-45 cable from either the control board or STU board.

## Overall Size & Weight

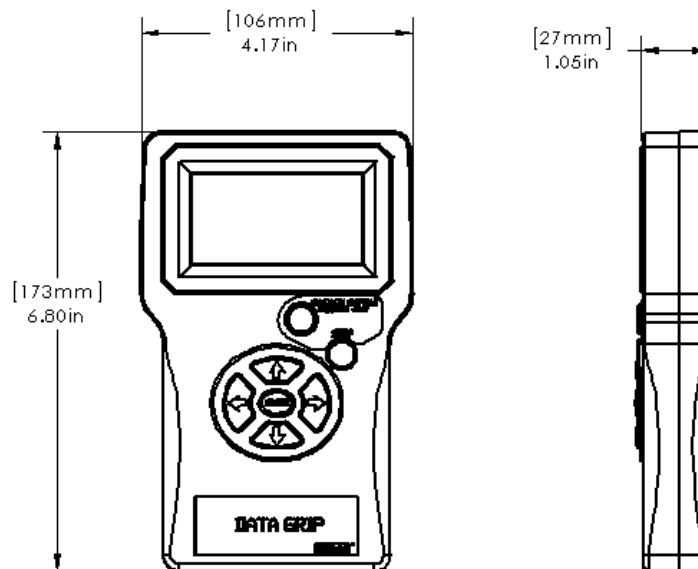

## Parts List

This is a list of replacement parts that may be necessary to have the DATA Grip function properly.

Part No.	Description	Contains
84.65.6	STU Replacement Kit	STU Assembly, Velcro, Inst. Sheet
84.27.3	RJ-45 Cable	25 foot patch cable
84.27.4	RJ-45 Cable	8 foot patch cable
84.27.5	RJ-45 Cable	50 foot patch cable
84.27.6	RJ-45 Cable	75 foot patch cable
84.65.28	IQ-85 Replacement Board for Atlas	IQ-85 control board

# Installation

---

The STU (Signal Transfer Unit) must be connected between the IQ-85 (844P) board and the laundry machine.

- If the STU is not already wired to the laundry machine, determine whether the 844P will be operated in the NORMAL, RELAY or SEQUENCE mode. Then wire the STU to the laundry machine as shown in the **STU Wiring Configuration** charts in the Atlas Installation Instructions (I-907).
- Next, connect the STU to the IQ-85 board with an RJ-45 Patch Cable.  
**NOTE:** The STU must be connected to the IQ-85 board for the DATA GRIP to work.
- Finally, connect the DATA GRIP to the IQ-85 or the STU board with an RJ-45 Patch Cable.

Up to thirty formulas may be programmed into the DATA GRIP. Most of the action screens are intuitive and easily understood. You can always use the **PROGRAM-EXIT** button (Bleach Defeat button) to back out of a display or to keep going backward until you find the display you are looking for. Use the **ENTER** button to activate the display that is shown on the DATA GRIP screen.

The buttons on the face of the DATA GRIP are as follows:

- **BLEACH DEFEAT (*Program-Exit*)**  
Pressing this button will toggle the Bleach pump 'off' or 'on'.  
Otherwise, it is used as a **PROGRAM-EXIT** button to 'back up' one screen at a time in order to get back to the previous menu screen.
- **STOP**  
Used to, immediately, stop a pump while in operating mode.  
Used to edit custom Formula, Chemical and Account Type names in the program mode.
- **ENTER**  
Used to 'go to' the next screen or to take an action that is shown on the display screen.  
When a value is keyed into the DATA GRIP, the ENTER button must be pressed for the value to be programmed.
- **DIRECTION ARROWS (↑ ↓ ← →)**  
Are used intuitively to increase or decrease display numbers or to move about the display.

When the dispenser is powered up, the DATA GRIP screen will activate. The following information will be displayed:

- Formula number.
- Total load count of the displayed formula.
- All of the pumps indicated by a pump number. The DATA GRIP will show six pumps no matter how many pumps are actually being used.
- The formula 'name' (i.e. *Sheets-White*).
- The product being dispensed (or if a pump is not presently running, the last product dispensed (i.e. *Sour*).
- BLEACH DEFEAT status (i.e. *Off*)

**Note:** When in this initial display mode, depressing the left arrow key several times will *darken* the display. Depressing the right arrow key several times will *lighten* the display.

\*\*\*\*\* IMPORTANT \*\*\*\*\*

**BEFORE USING THIS PRODUCT, PLEASE READ THE NOTE BELOW AND CLEAR ALL PROGRAMS ON INITIAL USAGE OF THIS PRODUCT.**

**ON THE VERY FIRST USAGE OF THE DATA GRIP (NEW OUT OF THE BOX) CONNECT THE DATA GRIP TO THE LAUNDRY SYSTEM AS DESCRIBED ABOVE. POWER IT UP, ENTER PROGRAMMING AND PROCEED TO THE UTILITY MENU. "CLEAR ALL PROGRAMS" BEFORE USING THE DATA GRIP FOR THE FIRST TIME. THIS WILL ONLY NEED TO BE DONE AT INITIAL USAGE. IT IS NOT NECESSARY TO CLEAR ALL PROGRAMS AFTER THE INITIAL CLEARING. SEE PROGRAMMING SECTION BELOW TO NAVIGATE TO UTILITY MENU. PAGES 9 AND 10 OF THIS INSTRUCTION MANUAL SHOW THE OPTIONS AND HOW TO "CLEAR ALL PROGRAMS."**

**ALWAYS SEND A PROGRAM FILE FROM A DATA GRIP TO EVERY ATLAS THAT IS BEING SET UP. THE DATA GRIP THAT IS BEING USED TO SEND THE FILE MUST HAVE BEEN CLEARED AT INITIAL USAGE AS DESCRIBED IN THE PREVIOUS PARAGRAPH. THE PROGRAM FILE CAN BE A FILE THAT CONSIST OF NO SET UP OR A PROGRAM FILE THAT WAS USED ON A PREVIOUS SETUP**

**ACCESS AND USER CODES:** The access and user codes **MUST** match exactly when you connect a DATA GRIP to an Atlas Laundry Dispenser. For a new out of the box Atlas and DATA GRIP, the access and user codes will both be set to zero and will connect fine. For a new DATA GRIP and a used or installed Atlas, the access codes must match and resetting the Atlas Control Board can be done through shorting the test points on the board. If the Data Grip is previously used and the Atlas Laundry system is previously used and the passwords do not match, each will have to be reset and resetting the Atlas Control Board can be done through shorting the test points on the board. When you reset the password on the Data Grip, **ALL COST AND PRICE INFORMATION WILL BE LOST IN THE DATA GRIP.**

# Operation

## How to Program the Unit. Before using this product, clear all programs.

DATA GRIP V2.1  
ENTER ACCESS OR  
USER ACCESS CODE  
= 0000  
↑  
PRESS ENTER TO PASS  
PRESS EXIT TO RETURN

DO YOU WANT TO SYNC  
WITH THE DISPENSER?  
➔ NO (SKIP)  
UPDATE REMOTE  
UPDATE DISPENSER

➔ FOLDER 1  
FOLDER 2  
FOLDER 3  
FOLDER 4  
FOLDER 5  
FOLDER 6  
FOLDER 7  
FOLDER 8

MAIN  
➔ *SETUP*  
CONFIGURE  
UTILITY  
PRIME PUMP  
CALIBRATE  
DATA MANAGEMENT

- 1) Press ENTER to access programming.
- 2) Use the right and left buttons to navigate to the 4 digits and use the up and down buttons to change the digits so that they read the 4 digit numeric code. The factory default code is 0000. (See Set Access Code for detailed information)
- 3) Press ENTER.
- 4) Using the up and down arrow buttons select the desired Program to ENTER and modify. Each program can have up to 30 Formulas. When you ENTER a Program all changes that you are making are modified in that program. Also when going to the Utility menu the Sending and Capturing features are sending and capturing the program that has been entered.
- 5) Using the up and down arrow buttons select the appropriate sync option.
- 6) Press ENTER.  
**Note:** If the remote is entering programming for the first time since it was last powered up the DO YOU WANT TO SYNC screen will be displayed. Otherwise this screen will be skipped and the MAIN MENU will be displayed.
- 7) Using the up and down buttons select an area to ENTER and begin setup or programming.
- 8) Press ENTER.

**The illustrations and text in the preceding pages discuss the various menus, programming and set up procedures.**

### Main Menu

Move the cursor up and down to the desired menu and press ENTER. The following pages in this instruction manual describe the function and how to program the features within the various menus.

## SETUP

- ➔ *Clear Load Counts*
- Pump Volume
- Formula Lockout
- Set Sequence (Drain)
- Set Units
- Test Formulas

## CLEAR LOAD COUNTS?

YES      Clear Loads

➔ No      (exit)

(All Dispenser load counts  
to be cleared)

## Pump Volume

FORMULA = 01 ←

Use Arrow Keys  
Press ENTER to Select

F01	L1	L2	Del
P1	▶000	000s	000s
P2	000	000s	000s
P3	000	000s	000s
P4	000	000s	000s
P5	000	000s	000s
P6	000	000s	000s
P7	000s		Time

## Setup Menu

Move the cursor to each menu selection and press ENTER to modify. See details below of each menu option.

### Clear Load Counts

- 1) The Load Count screen is self explanatory. Select with the arrow then press ENTER. This will clear and reset the load counts in all of the formulas back to zero.

### Pump Volume

*First Screen – Selecting formula to be programmed.*

- 1) Select the Formula number with the up and down buttons.
- 2) Press ENTER. The next screen will display the level 1 and 2 and delay settings.

*Second Screen – Pump run and delay times and flush time.*

- 3) Each programmable field shown on this screen represents LEVEL 1, LEVEL 2 and DELAY for each pump. Pumps are listed on the left side P1-P7. **Note:** P7 is the flush when flush system is activated.
- 4) Using the arrow keys navigate to the desired location to be programmed.
- 5) Press the ENTER key and the first zero far right of that field will begin to flash. Move the cursor under the desired digit to make adjustments of 0-9. Set the values so that the three character field shows the desired value. (i.e. 023 or 115) The units available are s = seconds, ml = milliliters and oz = ounces. Units can be changed in the Units selection menu. *Note: ml and oz require the use of the calibration system – see calibration section for instruction.*
- 6) Press the ENTER key and that value will be stored.
- 7) Repeat these steps to set other values on this screen.
- 8) Use the PROGRAM –EXIT button to back out to the previous screen to move to a new formula.

\*Level Mode is automatically turned “on” when a value is entered into any L2 setting

FORMULA LOCKOUT

➔ FORMULA= 03  
Select, Press ENTER

TIME in MINS = 23

Press ENTER to Save

FORMULA LOCKOUT

FORMULA= 03  
Select, Press ENTER

➔ TIME in MINS = 23 ↑

Press ENTER to Save

SET SEQUENCE

➔ FORMULA = 03  
SEQUENCE = 04

\* \* \* \*

1 2 3 4 5 6 7 F

Press ENTER to Save

SET SEQUENCE

FORMULA = 03  
➔ SEQUENCE = 04

\* \* \* \*

1 2 3 4 5 6 7 F

Press ENTER to Save

SET SEQUENCE

FORMULA = 03  
SEQUENCE = 04

\* \* \* \*

1 2 3 4 5 6 7 F  
↑

Press ENTER to Save

### Formula Lockout

- 1) Using the up and down buttons select the Formula number. Press ENTER.
- 2) Using the arrow buttons move the cursor to the two digit selection and make adjustments 0-9. Set the values to read the desired LOCKOUT time in minutes.
- 3) Press ENTER to save.
- 4) Input the same information for the other Formulas.
- 5) Use the **PROGRAM-EXIT** button to back up to the SETUP screen.

### Set Sequence

**Note:** In order to use the sequence mode the STU must be wired for the SEQUENCE MODE as shown in the 844P Atlas installation manual.

- 1) Press ENTER and use the up or down buttons to select the Formula number.
- 2) Press ENTER and use the up or down buttons to select the sequence 'event' (1 thru 16) closest to the time activation of the selected pump.
- 3) Press ENTER and use the left and right buttons to select the pump to be activated and press the up arrow to select it. An \* will appear above the selected pump (to deselect press the down arrow). Up to three pumps may be selected to run at the same time.

**Note:** The 'F' means 'Final Event', (not Flush) and it must be selected when finished. The final event is used to reset the sequence system on the last trigger signal from the laundry machine.

To check the sequence programming, perform steps 1 and 2 and scroll thru the events looking for the "\*" above the appropriate pumps.

```

SET UNITS

Set Units to:
  → TIME
    ENGLISH
    METRIC

Press ENTER to Save

```

```

TIME                →--DATA
ACCEPTED--

```

```

ENGLISH / METRIC
  ↓

```

```

--DATA ACCEPTED--

WARNING !!
Pumps must be
calibrated before
using the volume
feature.

```

```

FORMULA TEST
  ↑
Formula = 1
  ↓
← Pump 1 Level 1 →

```

### Set Units

- 1) Move the cursor up and down to the desired unit of measure. Time = seconds, English = Fluid Ounces, and Metric = milliliters.
- 2) Press ENTER to set the desired units.

**Note:** If English or Metric units are selected, a reminder to calibrate the pumps will be displayed, and the system will switch over the pump calibration screen. See Page 13 for more information on Calibration.

### Test Formulas

This feature allows each pump and flush to be tested manually. The function of this feature will allow the programmed amount of pump run time and flush time to be operated manually.

- 1) Move to the desired formula using the “up” and “down” buttons.
- 2) Move to the desired Pump and Level using the “right” and “left” buttons.
- 3) Press the “ENTER” button and the pump will run the amount of time that has been programmed for the selected formula/pump level.

## CONFIGURE

- ➔ *Set Level Mode*
- Set Operate Mode
- Set Flush Mode
- Load Count Select
- Bleach Def Select
- Set Default Formula
- ENTER Program Names

## LEVEL MODE

- Set Level Mode
- ➔ Off
- On
- Press ENTER to Save

## OPERATE MODE

- Set operate mode
- ➔ NORMAL
- RELAY
- SEQUENCE
- Press ENTER to Save

## FLUSH MODE

- Set Flush Mode
- ➔ ON
- OFF
- Press ENTER to Save

## Configure Menu

Move the cursor to each menu selection and press ENTER to modify. See details below of each menu option.

### Set Level Mode

- 1) The Level Mode allows you to choose multiple levels of pump programming. Select ON or OFF with the up and down buttons.
- 2) Press ENTER.

**\*Level Mode is automatically turned on when a value is added to the L2 setting under the Pump Volume setting.**

**\*Load Count Pump resets Level Mode**

### Set Operate Mode

- 1) Use the up and down buttons to select the desired operation mode.
- 2) Press ENTER.

#### Note:

- NORMAL = programmed formulas into DEMA laundry dispenser, use remote or Auto Formula Select to select formulas.
- RELAY = formulas are programmed into the laundry machine and only a flush is programmed into the DEMA laundry dispenser.
- SEQUENCE = uses a single trigger signal from laundry machine and Normal programming features.

### Set Flush Mode

- 1) The Flush mode is used in conjunction with a flush manifold system. Select the ON or OFF with the up and down buttons
- 2) Then press ENTER.

LOAD COUNT PUMP

➡FORMULA = 01  
Select, Press ENTER

PUMP NUMBER = 4

Press ENTER to Save

LOAD COUNT PUMP

FORMULA = 01  
Select, Press ENTER

➡PUMP NUMBER = 4

Press ENTER to Save

BLEACH DEFEAT PUMP

No Bleach Pump Active

Use up or down arrow keys  
SAVE --- press ENTER

SET DEFAULT FORMULA

Go to the formula  
after each load count

NO DEFAULT FORMULA

Use Arrow KEYS  
Press ENTER to Select

### Load Count Select

- 1) Select the Formula with up and down buttons.
- 2) Press ENTER.
- 3) Select the Load Count Pump with the up and down buttons.
- 4) Press ENTER to save.

**Note:** Each formula has a specific load count pump. It is necessary to program a load count pump for each formula to be used in application. The Load Count Pump resets the Level Mode. It is recommended that the last pump to be used on each formula is designated as the Load Count Pump.

### Bleach Def Select

- 1) No Bleach Pump Active is the default.
- 2) Press up or down arrows to select bleach pump.
- 3) Press ENTER to save.
- 4) This activates the Bleach defect button on USM, ED SM OR DATA GRIP. If no Bleach Pump Active, then this button is not functional during normal operations.

**Note:** Only one bleach pump can be selected for each DEMA laundry dispenser.

### Default Formula

Default formula is an optional feature that can allow the system to automatically change to a known formula after the load count pump is run. It can be used as a formula that would be safe for any type of load in the event that the end user does not change the formula when necessary.

- 1) Select the Formula that will be the default formula with up and down buttons. One of the choices is "NO DEFAULT FORMULA" if you do use a default formula.
- 2) Press ENTER to save.





FACTORY DEFAULT  
➔ YES RESTORE  
NO (exit)

WARNING\*\*\*\*\*WARNING  
\*\*YOU ARE ABOUT TO\*\*  
\*\*RESET EVERYTHING\*\*  
\*\*\*\*\*  
YES RESET MEMORY  
NO (EXIT)  
WARNING\*\*\*\*\*WARNING

PRIME PUMP  
PRIME PUMP 1  
↑  
↓  
Press ENTER to start  
or stop pump

CALIBRATE  
➔ Pump 1 00.0 oz/min  
Pump 2 00.0 oz/min  
Pump 3 00.0 oz/min  
Pump 4 00.0 oz/min  
Pump 5 00.0 oz/min  
Pump 6 00.0 oz/min  
Press ENTER to Start

Calibrating Pump 1  
ENTER to continue

### Factory Default – Resetting a single chemical program

- 1) Use the Up and Down buttons to select Yes.
- 2) Press ENTER – The “Restoring Factory Defaults – Please Stand By” screen will display. Allow the DATA GRIP to finish this process before pressing any buttons. Utility screen is displayed the process is complete.

**Note:** This will reset the current program to its original condition from DEMA. All programming setups and stored files are removed. This will only reset the single program that was entered which could have been any program 1-8. To reset every formula, use Clear All Formulas. This change only applies to the DATA GRIP not the IQ-85 board. To reset the IQ-85 transfer the selected program file from the DATA GRIP to the IQ-85.

**Clear All Programs-** Resets every chemical program to its original condition from DEMA. All settings and data will be lost. Use only for a new install or a clean DATA GRIP.

### Prime Pump Menu

- 1) Use the up and down arrows, select the pump to prime.
- 2) Press ENTER button to start the pump.
- 3) Press ENTER button to stop the pump.

### Calibration Menu

**Note:** When you ENTER the calibration system the “Set Units” screen will appear. It is necessary to choose English (oz) or metric (ml). Once the units have been chosen press ENTER to set and proceed to calibration screen.

It will be necessary to measure the output of the pump with either a measuring cup or graduated cylinder.

#### *Calibration step 1*

- 1) Using the up and down buttons, select the pump to be calibrated.
- 2) Press the ENTER button to start the pump. With the measuring cup or graduated cylinder start collecting the media.
- 3) Press the ENTER button to stop the pump when the desired volume of measurement is achieved. This volume does not need to be specific to the application. To improve accuracy, pump a minimal of 8 oz or 250ml. The more that is pumped the better the accuracy.

ENTER volume pumped

Vol pumped = 30.0  
 ↑

Press ENTER to Save  
 Press EXIT to Cancel

CALIBRATE

➔ Pump 1 14.5.oz/min  
 Pump 2 00.0 oz/min  
 Pump 3 00.0 oz/min  
 Pump 4 00.0 oz/min  
 Pump 5 00.0 oz/min  
 Pump 6 00.0 oz/min

Press ENTER to Start

MAIN

SETUP  
 CONFIGURE  
 UTILITY  
 PRIME PUMP  
 CALIBRATE  
 ➔ **DATA MANAGEMENT**  
 MAINTENANCE

DATA MANAGEMENT

➔ **SET DATE**  
 SET TIME  
 ACCOUNT INFORMATION  
 MACHINE INFORMATION  
 COST SETUP  
 REPORT SETUP

➔ JANUARY, 2009

➔		1	2	3		
4	5	6	7	8	9	10
11	12	13	14	15	16	17
18	19	20	21	22	23	24
25	26	27	28	29	30	31

DATA MANAGEMENT

SET DATE  
 ➔ **SET TIME**  
 ACCOUNT INFORMATION  
 MACHINE INFORMATION  
 COST SETUP  
 REPORT SETUP

**Calibration step 2**

- 1) Using the left and right buttons navigate the various digits and use the up and down buttons to change the numbers to read the amount of volume dispensed from the previous step.
- 2) Press ENTER to save the value.
- 3) The DATA GRIP will display the pump rate on the calibration screen.
- 4) Repeat this process for the remaining pumps.

**Note:** It is possible to manually change the pump rates on the calibration screen.

**Manually Set Pump Rate**

- 1) Simply move the cursor to the desired pump
- 2) Press the right arrow button. The far right digit will begin to flash.
- 3) Use the up and down arrows to change values and the left and right arrows to move the cursor to other digits.

**Data Management Menu**

This is used to setup the data management features. Move the cursor to DATA MANAGEMENT and press ENTER.

**Set Date**

This is used to set the date of the DATA GRIP. Move the cursor to SET DATE and press ENTER.

**Month and year**

Month and year are changed by pressing the left or right arrow buttons. The left will decrease and the right will increase.

**Date within month**

The date of a given month is changed by pushing the down arrow button so that the cursor arrow moves down near the month calendar. Then the left and right arrow buttons are used to move the day of the month.

**Set Time**

This is used to set the time of the DATA GRIP. There are two formats that can be used.

- 12 Hour format (AM and PM)
- 24 Hour format (Military)

SET TIME  
 ➔ 12 HOUR DISPLAY  
 ↑  
 9:49 AM

SET TIME  
 12 HOUR DISPLAY  
 ➔ 9:49 AM  
 ↑

DATA MANAGEMENT  
 SET DATE  
 SET TIME  
 ➔ **ACCOUNT INFORMATION**  
 MACHINE INFORMATION  
 COST SETUP  
 REPORT SETUP

ACCOUNT INFORMATION  
 ➔ NAME:  
*Name of account here*  
 ➔ NUMBER: *account no. here*  
 ➔ SET ACCOUNT TYPE  
 PRESS ENTER TO SELECT

ACCOUNT INFORMATION  
 NAME:  
*Name of account here*  
 ↑  
 NUMBER: *account no. here*  
 SET ACCOUNT TYPE  
 PRESS ENTER TO SELECT

ACCOUNT INFORMATION  
 NAME:  
*Name of account here*  
 NUMBER: *account no. here*  
 ↑  
 SET ACCOUNT TYPE  
 PRESS ENTER TO SELECT

## 12 or 24 Hour Format

Use the up and down arrow buttons to move the cursor to either the clock format or time.

Time format

- 1) Press the right arrow button at each option to change the setting.
- 2) Use the up and down arrow buttons to change the setting. Press ENTER to make the change.

Time

- 1) Press the right arrow button.
- 2) Navigate to the hour, minute and AM/PM (for 12 hour format) using the right and left arrow buttons. Use the up and down arrow buttons to adjust the time. Once the desired time has been set, press ENTER to make the change.

## Account Information

This is used to give a name, account number and assign formulas to account types. This information will appear on the data report.

- 1) Move cursor with the up and down arrow buttons to the ACCOUNT NAME, ACCOUNT NUMBER or ACCOUNT TYPE.
- 2) Press ENTER at the desired feature and a second cursor will appear under the entry field. Use the up and down arrow buttons to change the characters and the left and right arrow buttons to move the cursor for field entry.

## Account Name

Name—This is the name of the account. The name can be up to 20 characters long including spaces between words.

- 1) Use the left and right arrow buttons to move the cursor to the desired character.
- 2) Use the up and down arrow buttons to change the characters.
- 3) When the desired account name is displayed press ENTER to save.

## Account Number

This is the account number. The number can be both alpha and numeric. The account number can be up to 10 characters. This includes spaces between words.

- 1) Use the left and right arrow buttons to move the cursor to the desired character.
- 2) Use the up and down arrow buttons to change the characters.
- 3) When the desired account number is displayed press ENTER to save.

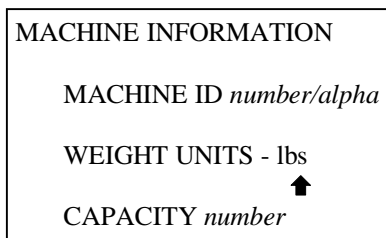
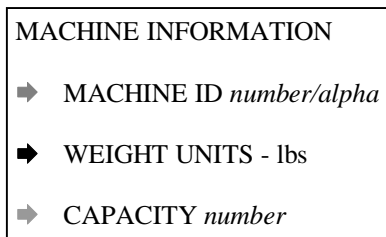
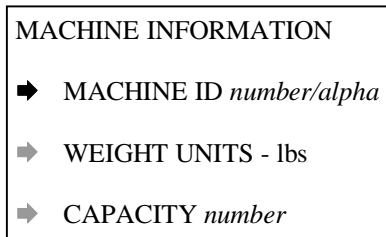
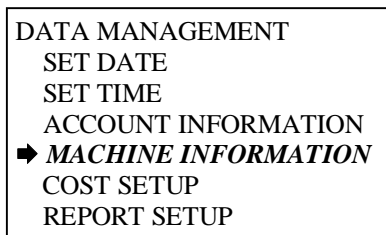
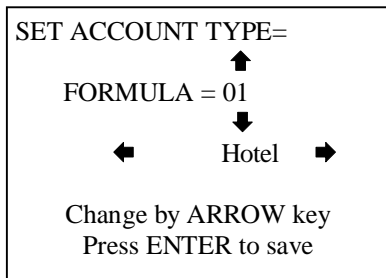

## Account Type

This is used to identify or direct specific formulas to an account type. For example, Formulas 1, 2 and 3 to service the linens for the housekeeping department of a hotel, while Formulas 4 and 5 may be used to service the dining facility at the same hotel. In this case Formulas 1, 2 and 3 could be assigned to the HOUSEKEEPING account type while Formulas 4 and 5 could be assigned to the FOOD & BEVERAGE account type. When reports are generated cost figures for each account type will be itemized separately.

- 1) Select the formula with the up and down arrow buttons.
- 2) Select the account type with the left and right buttons.
- 3) Once you have the desired setting, press ENTER to save.
- 4) Each formula that is to be assigned is done individually.

## Machine Information

This is used to identify the laundry machine within a given account or application site. Additionally, capacity of the machine (in weight) can be entered in weight (lbs) or units (Kg).

- 1) Move cursor with the up and down arrow buttons to Machine ID, Weight Units or Capacity.
- 2) Press ENTER at the desired feature and a second cursor will appear under the entry field.

## Machine ID

This can be both alpha and numeric. The entry can be up to 6 characters long. This includes spaces between words.

- 1) Use the left and right arrow buttons to move the cursor to the desired character.
- 2) Use the up and down arrow buttons to change the characters.
- 3) When the desired machine ID is displayed press ENTER to save.

## Weight Unit

This can be pounds or kilograms.

- 1) Use the up and down buttons to change toggle between lbs and kg.
- 2) When a desired weight unit is displayed press ENTER to save.

MACHINE INFORMATION  
MACHINE ID *number/alpha*  
WEIGHT UNITS - lbs  
CAPACITY *number*  
↑

DATA MANAGEMENT  
SET DATE  
SET TIME  
ACCOUNT INFORMATION  
MACHINE INFORMATION  
➔ **COST SETUP**  
REPORT SETUP

COST SETUP  
MONETARY UNITS: \$  
VOLUME UNITS: GAL  
SHIFT INFORMATION  
PRODUCT COST  
PRICE

COST SETUP  
MONETARY UNITS: \$  
VOLUME UNITS: GAL  
SHIFT INFORMATION  
PRODUCT COST  
PRICE

### Capacity

This is a number that represents the size of the machine. Example a 125lb machine. The number can be up to 3 characters. If the machine capacity is a two digit number a zero should be the first number. Example a 50lb machine should be entered as "050" This is important when reporting cost in 100 lb.

- 1) Use the left and right arrow buttons to move the cursor to the desired character.
- 2) Use the up and down arrow buttons to change the characters.
- 3) When the desired machine capacity is displayed press ENTER to save.

### Cost Setup

This allows the system to be setup with units and associated costs. When setup appropriately the system will generate reports that will calculate various cost related information.

### Monetary Units

This is used to change the unit of currency symbol. The choices are dollars, pounds and euros.

- 1) Press ENTER and a cursor will appear next to the currency symbol displayed.
- 2) Use the up and down arrow buttons to toggle between the three choices. Press ENTER when desired choice is displayed.

### Volume Units

This is used to change the unit of volume that is used to calculate usage of the chemical products. The choices are gallons and liters.

- 1) Press ENTER and a cursor will appear next to the units displayed.
- 2) Use the up and down arrow buttons to toggle between the two choices.
- 3) Press ENTER when the desired choice is displayed.

```

COST SETUP
  MONITARY UNITS:  $
  VOLUME UNITS:   GAL
➔ SHIFT INFORMATION
  PRODUCT COST
  PRICE

```

```

➔ NUMBER OF SHIFTS= 3
  SHIFT 1
  BEGINS:      08:00AM
  SHIFT 2
  BEGINS:      04:00PM
  SHIFT 3
  BEGINS:      12:00AM

```

```

COST SETUP
  MONITARY UNITS:  $
  VOLUME UNITS:   GAL
  SHIFT INFORMATION
➔ PRODUCT COST
  PRICE

```

```

PRODUCT COST
➔ P1 $      18.50/GAL
  P2 $      16.00/GAL
  P3 $      19.25/GAL
  P4 $      21.23/GAL
  P5 $       1.98/GAL
  P6 $      11.55/GAL

```

```

ENTER COST FOR
PRODUCT 1

$ 000018.50/GAL
  ↑

```

```

COST SETUP
  MONITARY UNITS:  $
  VOLUME UNITS:   GAL
  SHIFT INFORMATION
  PRODUCT COST
➔ PRICE

```

**Shift Information**

This allows the system to track usage during various shifts. Up to 3 shifts can be setup. Press ENTER to modify the shift setup.

- 1) With the cursor next to the “number of shifts” press ENTER.
- 2) Modify the number of shifts using the up and down arrow buttons.
- 3) When the number of shifts reads the desired setting press ENTER.
- 4) For each shift a start time needs to be entered. Move the cursor to the various shifts and press ENTER.
- 5) Use the left and right arrow buttons to move the cursor left and right and use the up and down buttons to adjust the hours, minutes and am/pm for a beginning shift time. The system will only display the number of shifts that has been entered at the top of the screen.
- 6) Repeat process for shift 2 and 3 if necessary.

**Product Cost**

This allows a cost to be entered for each product. The Product Cost Entered Here is only used in Downloaded Detailed Reports. The cost will be based on the monetary units and the volume units for each chemical product. Press ENTER to modify the product cost.

- 1) Select the product P1-P6 by using the up and down arrow buttons.
- 2) Press ENTER to modify the desired product cost.
- 3) Use the left and right arrow buttons to select the decimal place to modify.
- 4) Press ENTER to modify the desired decimal place.
- 5) Use the up and down arrow buttons to modify the decimal place (0-9).
- 6) Press ENTER when the cost reads the desired setting.

**Price**

This feature is be used to generate invoice pricing both in a written report. Press ENTER to setup this feature.

- 1) Use the up and down buttons to toggle through Price/Load and Price/100lb.
- 2) Press ENTER when desired invoicing method is shown.

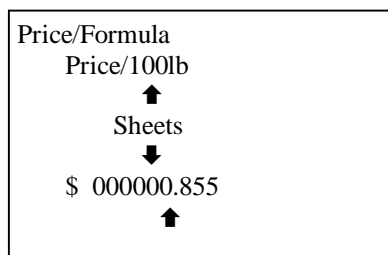
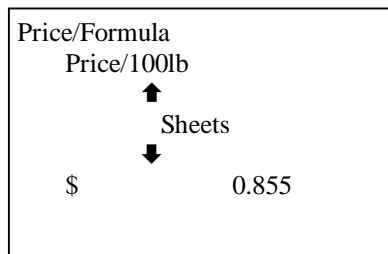
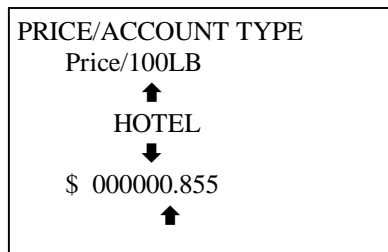
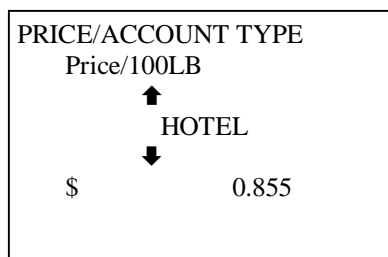
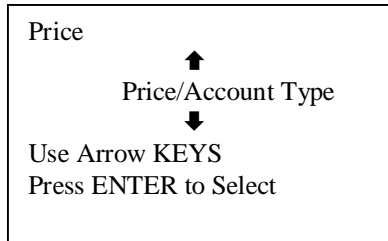
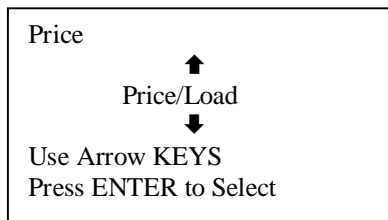

**When Price/Load or Price/100lb is chosen, it is necessary to choose how to itemize the invoice reporting, the two choices are Price/Formula or Price/Account Type.**

- 1) Use the up and down buttons to toggle through Price/Formula and Price/Account Type.
- 2) Press ENTER when desired itemization method is displayed.

**NOTE: The following pages will show how to set up for each individual pricing scheme. Please pay careful attention to which pricing scheme is selected and how to properly set that up.**

**Price/100lb and Price/Account Type**

Once the price per 100lb and price per account type is selected, then select the specific account type and enter in the price per 100 lb of laundry.

- 1) Use the up and down buttons to select the desired account type.
- 2) Press ENTER when the desired account type is displayed.
- 3) Use the right and left buttons to move cursor to the desired digit. Use the up and down buttons to change the value of each digit.
- 4) Press the ENTER button when the desired invoice price is displayed.

**Price/100lb and Price/Formula**

Once the price per 100lb and price per formula is selected, then select the specific formula and enter the price per 100lb of laundry.

- 1) Use the up and down buttons to select the desired formula.
- 2) Press ENTER when the desired formula is displayed.
- 3) Use the right and left buttons to move cursor to the desired digit. Use the up and down buttons to change the value of each digit.
- 4) Press the ENTER button when the desired invoice price is displayed.

```

PRICE/Account Type
Price/Load
  ↑
HOTEL
  ↓
$           0.855
  
```

```

PRICE/Account Type
Price/Load
  ↑
HOTEL
  ↓
$ 000000.855
  ↑
  
```

```

Price/Formula
Price/Load
  ↑
Sheets
  ↓
$           0.855
  
```

```

Price/Formula
Price/Load
  ↑
Sheets
  ↓
$ 000000.855
  ↑
  
```

```

DATA MANAGEMENT
SET DATE
SET TIME
ACCOUNT INFORMATION
MACHINE INFORMATION
COST SETUP
➔ REPORT SETUP
  
```

```

REPORT SETUP
➔ TYPE: COST/100LB
PERIOD: BILLING CYCLE
START: 01 JAN 2008
LENGTH: 30 DAYS
CLEAR ALL DATA
RUN REPORT
  
```

```

REPORT SETUP
TYPE: COST/100LB
  ↑
  
```

### Price/Load and Price/Account Type

If price per load and price per account type have been selected, then select the specific account type and enter in the price per load of laundry.

- 1) Use the up and down buttons to select the desired account type.
- 2) Press ENTER when the desired account type is displayed.
- 3) Use the right and left buttons to move cursor to the desired digit. Use the up and down buttons to change the value of each digit.
- 4) Press the ENTER button when the desired invoice price is displayed.

### Price/Load and Price/Formula

Once the price per load and the price per formula are selected, then select the specific formula and enter the price per load of laundry.

- 1) Use the up and down buttons to select the desired formula.
- 2) Press ENTER when the desired formula is displayed.
- 3) Use the right and left buttons to move cursor to the desired digit. Use the up and down buttons to change the value of each digit.
- 4) Press the ENTER button when the desired invoice price is displayed.

### Report Setup

These are additional report setting variables. Press ENTER to make changes.

### Type

This is the method of how cost will be calculated. There are three choices: Cost/100lb, Cost/1lb, Cost/Load

- 1) To make changes press ENTER.
- 2) Use the up and down arrow buttons to toggle through the three choices.
- 3) When the desired choice is displayed press ENTER.

### Note:

This setting applies to the machine and summary reports.

REPORT SETUP  
 TYPE: COST/100LB  
 ➔ PERIOD: BILLING CYCLE  
 START: 01 JAN 2008  
 LENGTH: 30 DAYS  
 CLEAR ALL DATA  
 RUN REPORT

REPORT SETUP  
 TYPE: COST/100LB  
 PERIOD: BILLING CYCLE  
 ↑

REPORT SETUP  
 TYPE: COST/100LB  
 PERIOD: BILLING CYCLE  
 ➔ START: 01 JAN 2008  
 LENGTH: 30 DAYS  
 CLEAR ALL DATA  
 RUN REPORT

➔ JANUARY, 2009  
 ➔           1 2 3  
 4 5 6 7 8 9 10  
 11 12 13 14 15 16 17  
 18 19 20 21 22 23 24  
 25 26 27 28 29 30 31

REPORT SETUP  
 TYPE: COST/100LB  
 PERIOD: BILLING CYCLE  
 START: 01 JAN 2008  
 ➔ LENGTH: 30 DAYS  
 CLEAR ALL DATA  
 RUN REPORT

REPORT SETUP  
 TYPE: COST/100LB  
  
 LENGTH: 30 DAYS  
 ↑

**Period**

This is used to set the period of time that the Data Grip will base reporting. The three choices are:

**Billing Cycle**

This is where a start date is set and then the length of billing cycle is entered in days. Once this has been setup, the system will continue to track the billing cycles as they start and finish.

**Billing Date**

This is where a day of the month is chosen and that is the last day of a given period of time. The first day is the next numeric day of the last month. Example: The 15th is set as the billing date. Reporting will be based on the 16th of the previous month to the 15th of current month.

**Note-**It is important to understand that the Data Grip is going to report the last fully completed window of time for both the billing cycle and billing date.

**Date to Date**

This is where a start and end date are entered and the report will be based on that window of time.

**Note-** the report screen will appear three different ways depending on how the PERIOD is set. In the example screen to the left the where it currently states “Length 30 days” can read as follows:

Billing Cycle= Length.....

Billing Date= will be blank (no text)

Date to Date= End Date....

**Billing Cycle**

- 1) Use the up and down buttons to move the cursor to the start.
- 2) Press ENTER to modify the start date.
- 3) **Month and year** - Month and year are changed by pressing the left or right arrow buttons. The left will decrease and the right will increase.
- 4) **Date within month** - The date of a given month is changed by pushing the down arrow button so that the cursor arrow moves down near the month calendar. Then the left and right arrow buttons are used to move.
- 5) Press ENTER when desired start date is displayed.
- 6) Move cursor to length using the up and down buttons.
- 7) Press ENTER to set the billing cycle length.
- 8) Use the up and down arrow buttons to increase or decrease the amount of days for the billing cycle length.
- 9) Press ENTER when desired billing cycle length is displayed.

REPORT SETUP  
 TYPE: COST/100LB  
 PERIOD: BILLING DATE  
 ➔ START: 01 JAN 2008  
  
 CLEAR ALL DATA  
 RUN REPORT

➔ JANUARY, 2009  
 ➔                   1 2 3  
 4 5 6 7 8 9 10  
 11 12 13 14 15 16 17  
 18 19 20 21 22 23 24  
 25 26 27 28 29 30 31

REPORT SETUP  
 TYPE: COST/100LB  
 PERIOD: DATE TO DATE  
 ➔ START: 01 JAN 2008  
 ➔ END: 31 JAN 2008  
 CLEAR ALL DATA  
 RUN REPORT

JANUARY, 2009  
                           1 2 3  
 4 5 6 7 8 9 10  
 11 12 13 14 15 16 17  
 18 19 20 21 22 23 24  
 25 26 27 28 29 30 31

REPORT SETUP  
 TYPE: COST/100LB  
 PERIOD: BILLING CYCLE  
 START: 01 JAN 2008  
 LENGTH: 28 DAYS  
 ➔ CLEAR ALL DATA  
 RUN REPORT

CLEAR ALL DATA  
  
 YES CLEAR DATA  
  
 ➔ NO (exit)

**Billing Date**

- 1) Use the up and down buttons to move the cursor to the start.
- 2) Press ENTER to modify the start date.
- 3) **Month and year** - Month and year are changed by pressing the left or right arrow buttons. The left will decrease and the right will increase.
- 4) **Date within month** - The date of a given month is changed by pushing the down arrow button so that the cursor arrow moves down near the month calendar. Then the left and right arrow buttons are used to move.
- 5) Press ENTER when desired start date is displayed

**Date to Date**

- 1) Use the up and down buttons to move the cursor to the start.
- 2) Press ENTER to modify the start date.
- 3) **Month and year** - Month and year are changed by pressing the left or right arrow buttons. The left will decrease and the right will increase.
- 4) **Date within month** - The date of a given month is changed by pushing the down arrow button so that the cursor arrow moves down near the month calendar. Then the left and right arrow buttons are used to move.
- 5) Press ENTER when desired start date is displayed.
- 6) Set the end date by moving cursor to the end and press ENTER.
- 7) Repeat preceding process to set the end date.

**Clear All Data**

This will clear all data that has been collected in the Data Grip memory. This will not remove or erase the programming and setup information.

- 1) Move cursor to clear all data and press ENTER.
- 2) Move cursor to Yes to clear data or No to exit and not clear data
- 3) With cursor next to Yes, press ENTER to clear and remove data from DATA GRIP.

```

REPORT SETUP
TYPE: COST/100LB
PERIOD: BILLING CYCLE
START: 01 JAN 2008
END: 31 JAN 2008
CLEAR ALL DATA
➔ RUN REPORT

```

```

RUN REPORT
➔ DATA SPREADSHEET
MACHINE REPORT
ACCOUNT SUMMARY
SHIFT REPORT
INVOICE REPORT

```

```

OUTPUT FILE NAME
DATA SPREAD SHEET

_____.CDF
↑

```

```

MAIN
SETUP
CONFIGURE
UTILITY
PRIME PUMP
CALIBRATE
DATA MANAGEMENT
➔ MAINTENANCE

```

```

MAINTENANCE
➔ Software          V0.70
USB Driver         V3.11
Dispenser Prog
DM Parameters

```

```

Software
Install Update?
➔ Yes Update Drive
No (exit)

```

## Run Report

This is for setting up the reports that will be extracted from the DATA GRIP. Press ENTER to setup reports

All of the reports listed on the RUN REPORT screen are designed to be loaded into a USB memory device. All of the reports are setup similar where a file name needs to be assigned. The file name can be 1-8 characters long.

- 1) Use the up and down arrow buttons to select the desired report.
- 2) Press ENTER to assign a file name.
- 3) Use the right and left arrow buttons to move to each of the eight character fields. At each character field the up and down arrow buttons can be used to modify the character.
- 4) When the desired file name is set press ENTER and the report will be generated.

## Maintenance Menu

Set the cursor on the maintenance option and press enter to select. This puts the program into the maintenance menu.

## Software Update

To update the software, make sure that a Flash Drive with the correct file on it is inserted into the unit. The file must be obtained from DEMA Engineering. The name of the file on the flash drive must be DEMA\_001.hex. If this file is not on the flash drive the software will not update.

- 1) Set the cursor on software and hit enter.
- 2) The program will search for the correct file. Confirm to update the driver by moving the cursor to Yes and hitting enter.
- 3) The program will install the update. This will take a few minutes.
- 4) The Data Grip will then reset and enter BITE MODE. Follow the on-screen instructions to finish the update.
- 5) When the Bite Mode Test Complete screen appears, unplug the Data Grip from the RJ-45 cord.
- 6) The unit should come back up as normal and be ready to go.

MAINTENANCE	
Software	V0.70
USB Driver	V3.11
➔ Dispenser Prog	
DM Parameters	

Dispenser Prog
➔ <b>Import 1 Program</b>
Import All Programs
Export 1 Program
Export All Programs

Import 1 Program
↑
_____PGM
↓
Use Arrow KEYS
Press Enter to Select

Import All Programs
↑
_____PGM
↓
Use Arrow KEYS
Press Enter to Select

Dispenser Prog
Import 1 Program
Import All Programs
➔ <b>Export 1 Program</b>
Export All Programs

## Dispenser Prog

To import and export 1 or all programs on the unit, this option will need to be selected. Use the arrow keys to select the option then press the ENTER button.

## Importing Programs

To import a program onto the Data Grip, use the arrow keys to select whether to import one or all programs. Use the ENTER button to select the option.

### For 1 Program

- 1) Insert the flash drive with the program already on the flash drive.
- 2) The unit will look for the programs on the flash drive and give a scrolling list of programs to import.
- 3) Use the up and down arrows to select the desired file to import on the Data Grip. Press the ENTER Button once selected.
- 4) Then use the up and down arrows to select the desired folder to put the file in. Press the ENTER Button once selected.
- 5) The unit will import the file and show a DATA ACCEPTED screen once complete.

### For All Programs

- 1) Insert the flash drive with the program already on the flash drive.
- 2) The unit will look for the programs on the flash drive and give a scrolling list of programs to import.
- 3) Use the up and down arrows to select the desired file to import on the Data Grip. Press the ENTER Button once selected.
- 4) The unit will import the file and show a DATA ACCEPTED screen once complete.

**Note: If a flash drive is not connected, the unit will not look for programs and will wait for a flash drive to be connected.**

## Exporting Programs

To export a program from the Data Grip to be used on another Data Grip or with another dispenser, use the up and down arrow keys to get to the desired selection and press the ENTER button to select the option.

Export 1 Program  
 ↑  
 \_\_\_\_\_PGM  
 ↓  
 Use Arrow KEYS  
 Press Enter to Select

Output File Name  
 Program File Name  
 \_\_\_\_\_PGM  
 ↑  
 Change by ARROW key  
 Press ENTER to Save

MAINTENANCE

Software	V0.70
USB Driver	V3.11
Dispenser Prog	
➔ DM Parameters	

DM Parameters

➔ Import DM Parameters  
 Export DM Parameters

Import All Programs  
 ↑  
 \_\_\_\_\_DMP  
 ↓  
 Use Arrow KEYS  
 Press Enter to Select

*For 1 Program*

- 1) Insert the flash drive for the program to be exported to.
- 2) Use the up and down arrows to select the desired folder where the program is located to export on to the flash drive. Press the ENTER Button once selected.
- 3) Then use the up and down arrows to select the desired program name for the file to be saved onto the flash drive.. Press the ENTER Button once selected.
- 4) The unit will export the file and show a DATA ACCEPTED screen once complete.

*For All Programs*

- 1) Insert the flash drive for the programs to be exported to.
- 2) Use the up and down arrows to select the desired file name to export to the flash drive. Press the ENTERButton once selected.
- 3) The unit will export the file and show a DATA ACCEPTED screen once complete.

**NOTE: If you select a file name that is already being used on the flash drive, the program will ask you if you want to overwrite the file or change the name.**

**DM Parameters**

To import and export the Data Management Parameters, use the arrow keys to select the DM Parameters setting and press the ENTER button to enter the DM Parameters Import/Export Menu

**Importing DM Parameters**

Once in the menu, select to import the DM Parameters and Press the ENTER button.

- 1) Insert the flash drive with the program already on the flash drive.
- 2) The unit will look for the programs on the flash drive and give a scrolling list of programs to import.
- 3) Use the up and down arrows to select the desired file to import on the Data Grip. Press the ENTER Button once selected.
- 4) Then use the up and down arrows to select the desired folder to put the file in. Press the ENTER Button once selected.
- 5) The unit will import the file and show a DATA ACCEPTED screen once complete

**Note: If a flash drive is not connected, the unit will not look for programs and will wait for a flash drive to be connected.**

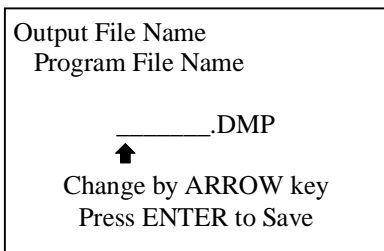
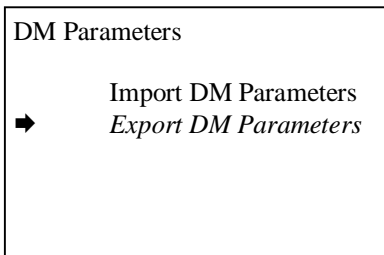

### Exporting DM Parameters

Once in the menu, select to export the DM Parameters and Press the ENTER button.

- 6) Insert the flash drive where the program will be exported to.
- 7) Use the up and down arrows to select the desired file name to export to the Data Grip. Press the ENTER Button once selected.
- 8) Then use the up and down arrows to select the desired folder to put the file in. Press the ENTER Button once selected.
- 9) The unit will import the file and show a DATA ACCEPTED screen once complete

**NOTE: If you select a file name that is already being used on the flash drive, the program will ask you if you want to overwrite the file or change the name.**

# Troubleshooting

---

Symptom	Probable Cause	Remedy
The Data Grip is not powering up	<ol style="list-style-type: none"> <li>1. There is no power to the unit it is connected to.</li> <li>2. One of the RJ-45 cables is not fully plugged in or damaged.</li> </ol>	<ol style="list-style-type: none"> <li>1. Check to make sure power is going to the Laundry Unit itself.</li> <li>2. Check the RJ-45 Cables to make sure it is hooked up from the Data Grip to the Control Board or from the Data Grip to the STU to the Control Board. Check the cables for damage. Replace if necessary.</li> </ol>
The Data Grip will not download reports or programs	<ol style="list-style-type: none"> <li>1. There is no flash drive in the Data Grip</li> <li>2.</li> </ol>	<ol style="list-style-type: none"> <li>1. Put a flash drive in the Data Grip and try to download the reports/programs again</li> <li>2.</li> </ol>

## Warranty

---

### Return Policy

*No merchandise may be returned for credit without DEMA® Engineering Company's written permission. Return Merchandise Authorization (RMA) number required in advance of return.*

### Warranty

*DEMA® products are warranted against defective material and workmanship under normal use and service for three years from the date of manufacture. This limited warranty does not apply to products that have a normal life shorter than one year or failure and damage caused by chemicals, corrosion, improper voltage supply, physical abuse or misapplication. Rubber and synthetic parts such as "O"-rings, diaphragms, squeeze tubing and gaskets are considered expendable and are not covered under warranty. This warranty is extended only to the original buyer of DEMA® products. If products are altered or repaired without prior approval of DEMA®, this warranty will be void.*

*Defective units or parts should be returned to the factory with transportation prepaid. If inspection shows them to be defective, they will be repaired or replaced without charge. F.O.B. factory DEMA® assumes no liability for damages. Return merchandise authorization number to return units for repair or replacement must be granted in advance of return.*

**DEMA Engineering Company**  
**10020 Big Bend Blvd.**  
**St. Louis, MO 63122**  
**(800) 325-3362 or (314) 966-3533**  
**www.demaeng.com**