

# DEMA 259B DRAIN MASTER Jr. INSTALLATION INSTRUCTION SHEET

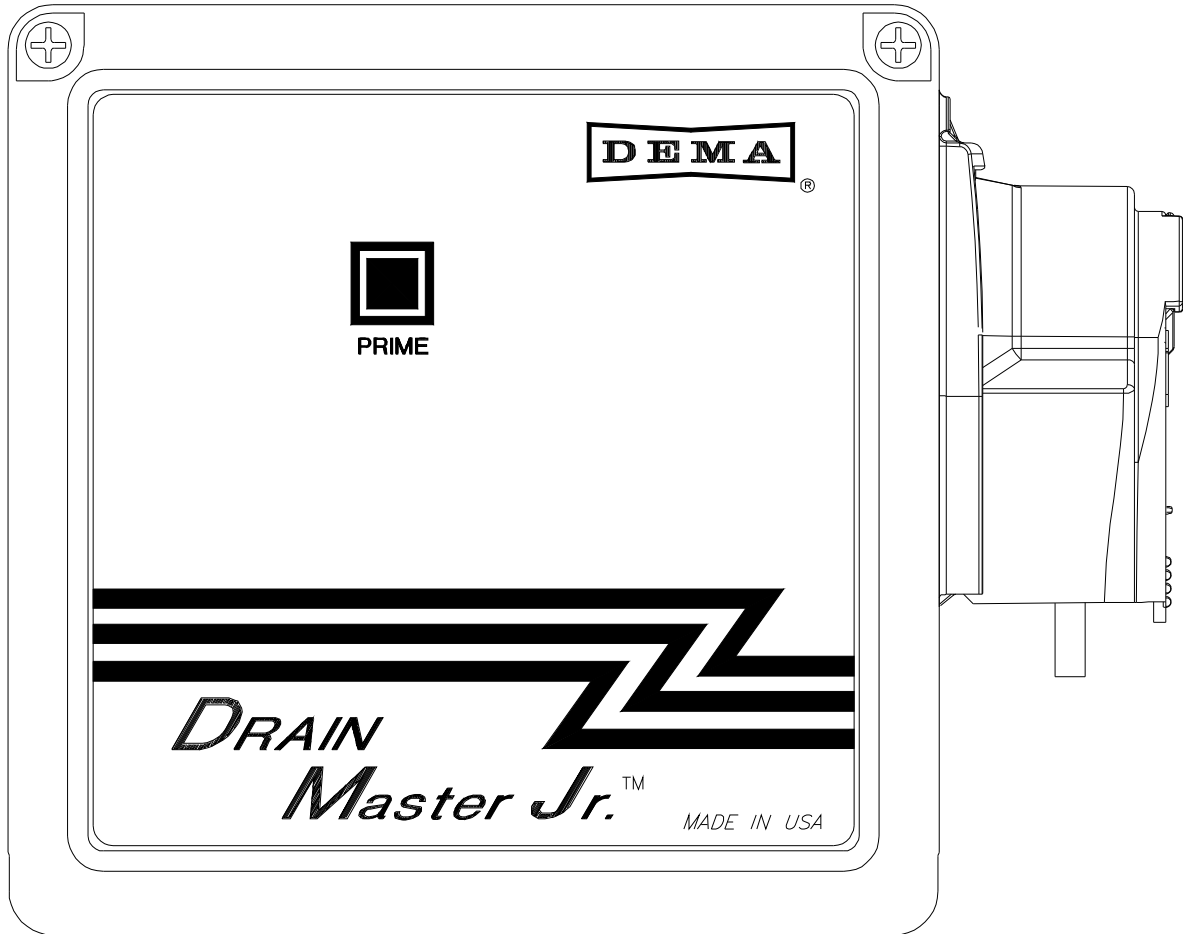

# DEMA 259B DRAIN MASTER Jr.

## INSTALLATION INSTRUCTION SHEET

### Summary

The 259B Drain Master is designed to feed chemicals into drains and grease traps to break up grease, detergent build up and eliminate odors. All programming is done by use of a set of DIP switches that determine the various times and amount of chemical to be dispensed. The squeeze tube for the peristaltic pump is available in either EPDM or Viton.

**Please read all instructions before proceeding with Drain Master installation.**

### Survey Location

Determine a location to hang the Drain Master on a wall near the drain or grease trap to be supplied with the chemical product. The location should be near an AC wall outlet. The Drain Master can be hung on the wall by use of the supplied wall bracket kit.

### Electrical Hookup:

Open the cover on the Drain Master and find the female power jack on the control board. Feed the male jack on the power cord through the split bushing at the bottom of the enclosure. Connect the power cord jack to the jack on control board. Connect the 9V battery to the control board and place battery in battery holder. At this point the "LED" on control board should be "on". Plug power cord into a 120V 60Hz wall outlet.

### Tubing Connections

Cut off the proper lengths of LDPE tubing that will reach from the container of product to the inlet of the Drain Master pump and the outlet of the pump to the drain or grease trap.

Insert the chemical supply tubing into the end of the 1/4" ID JG fitting located on the left side of the pump. The JG fitting must be inserted completely in order to ensure a good seal. The other end of the chemical supply tubing can be connected to the 10" PVC pickup tube that has been supplied. This should be done by slipping the LDPE tubing through the compression nut and sleeve and into the threaded end of the pickup tube until LDPE tubing is about 1/4" from the bottom of the pickup tube. The pickup tube can be placed in gallon containers of chemical products. If the pickup tube is not used, the supply tube should be properly secured to the supply container to assure that chemical product is delivered.

Insert the outlet tubing into the end of the 1/4" ID JG fitting located on the right side of the pump. **The JG fitting must be inserted completely in order to ensure a good seal.** The other end of the outlet tubing must be secured into drain or grease trap to assure that chemical product is properly delivered. It is suggested to use a 1/8" NPT male x 1/4" compression fitting when fitting discharge into the side of a drainpipe.

# DEMA 259B DRAIN MASTER Jr.

## INSTALLATION INSTRUCTION SHEET

### Programming:

Open the cover on the Drain Master. All of the DIP switches should be visible on the control board on the backside of the cover. **All of these switches must be in the “off” position to begin programming.**

**Time Set:** Find the DIP switch that corresponds to the closest hour of the current time. There are 12 DIP switches for AM and 12 for PM. After finding the correct switch flip it to the “on” position. The “time set” LED will go out.

**Feed Time:** Using the same switches set the hours in which the Drain Master should operate by switching the appropriate switch to the “on” position.

**Note:** If the DIP switch that was set for the “time set” is not a desirable “feed time”, simply turn that switch to the “off” position. But not until at least one feed time has been selected. This will insure that the “time set” will not be lost.

**Dosage:** There are a series of 6 DIP switches that are labeled “dosage”. The number labeled next to each switch indicates the number of ounces to be dispensed. Example: switch 2 will dispense 2 ounces of product. These may be added together for higher doses. Example: Switches 5 and 6 in the “on” position will dispense 11 ounces of product. The maximum is 21 ounces at each “feed time” that has been set.

**Reprogram:** Flip all the DIP switches to “off” position.

### Priming

After installation is complete the pump and tubing will need to be primed so that chemical product will be delivered when the Drain Master is running. This is simply done by pressing and releasing the prime button on the front of the Drain Master; the pump should begin to run. The pump will run for the amount of dose that has been set.

**Note:** At any time the Drain Master pump can be shut off by simply pushing the prime button again.

# DEMA 259B DRAIN MASTER Jr. INSTALLATION INSTRUCTION SHEET

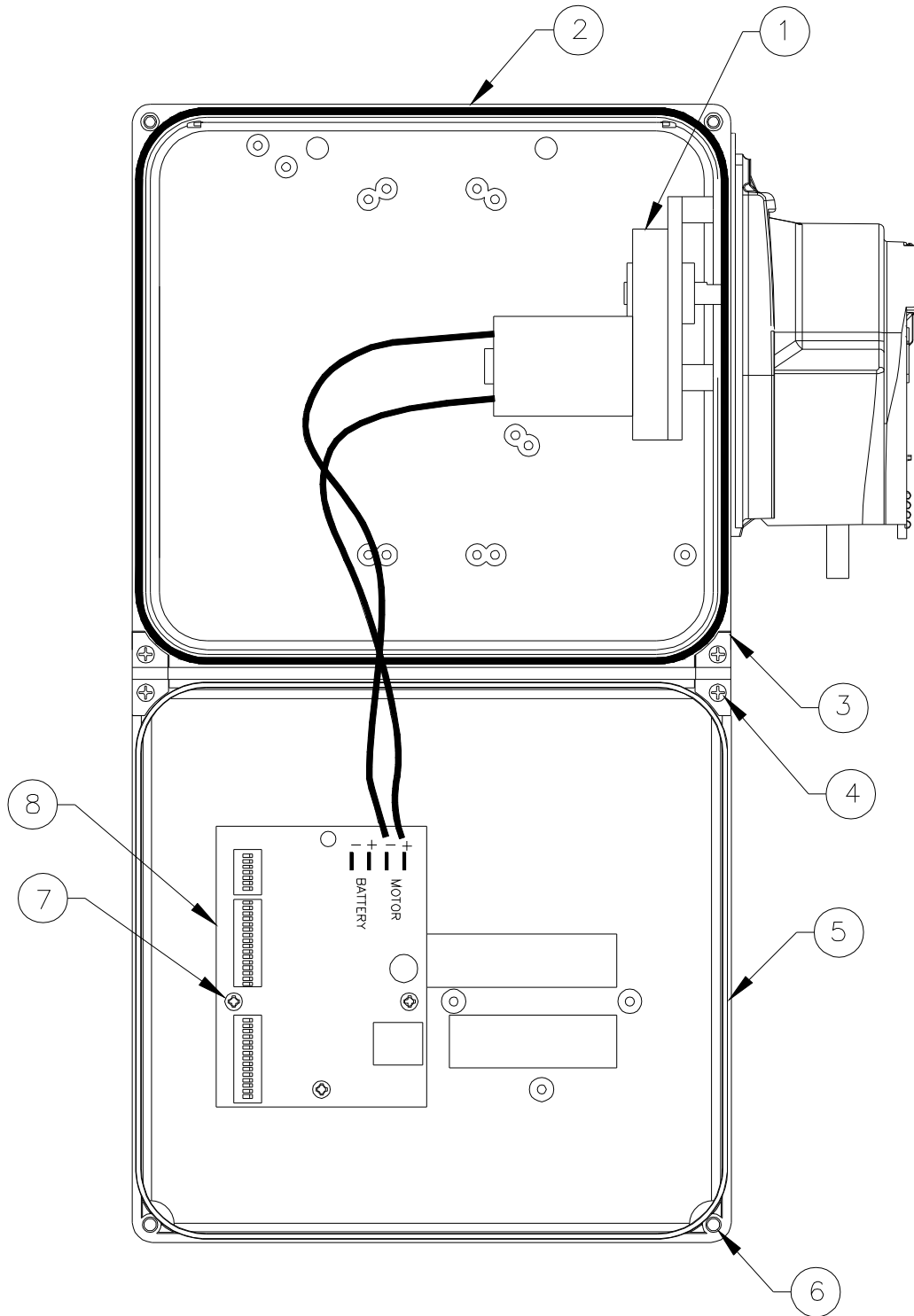

# DEMA 259B DRAIN MASTER Jr. INSTALLATION INSTRUCTION SHEET

<b>REPLACEMENT PARTS</b>			
<b>NO.</b>	<b>DEMA PART NO.</b>	<b>DESCRIPTION</b>	<b>QTY.</b>
1	25-66C	Gear Motor Assembly	1
2	81-40	Electrical Enclosure Assembly	1
3	81-23	Electrical Enclosure Hinge	2
4	81-19-1	Hinge Screw	2
5	81-44	Electrical Enclosure Lid	1
6	81-29-2	Captive Screw for Electrical Enclosure Cover	2
7	81-20-2	Control Board Screw	3
8	25-122-1	Drain Master Electronic Control Board	1

<b>INSTALLATION KIT PARTS (NOT SHOWN ON DRAWING)</b>		
<b>DEMA PART NO.</b>	<b>DESCRIPTION</b>	<b>QTY.</b>
81-16-1	Tie Wrap 8" lg.	4
81-182-1	¼" x ¼" JG Union	2
25-68-20	20 Ft of ¼" LDPE Tubing (white)	1
80-66	10" Pick Up Tube Assembly	1
81-1	Wall Bracket Kit	1
66-122	#8 Screw and Anchor Kit	1
25-69	AC to DC Adapter (U.S., 120V 60Hz – 12VDC)	1

# DEMA 259B DRAIN MASTER Jr. INSTALLATION INSTRUCTION SHEET

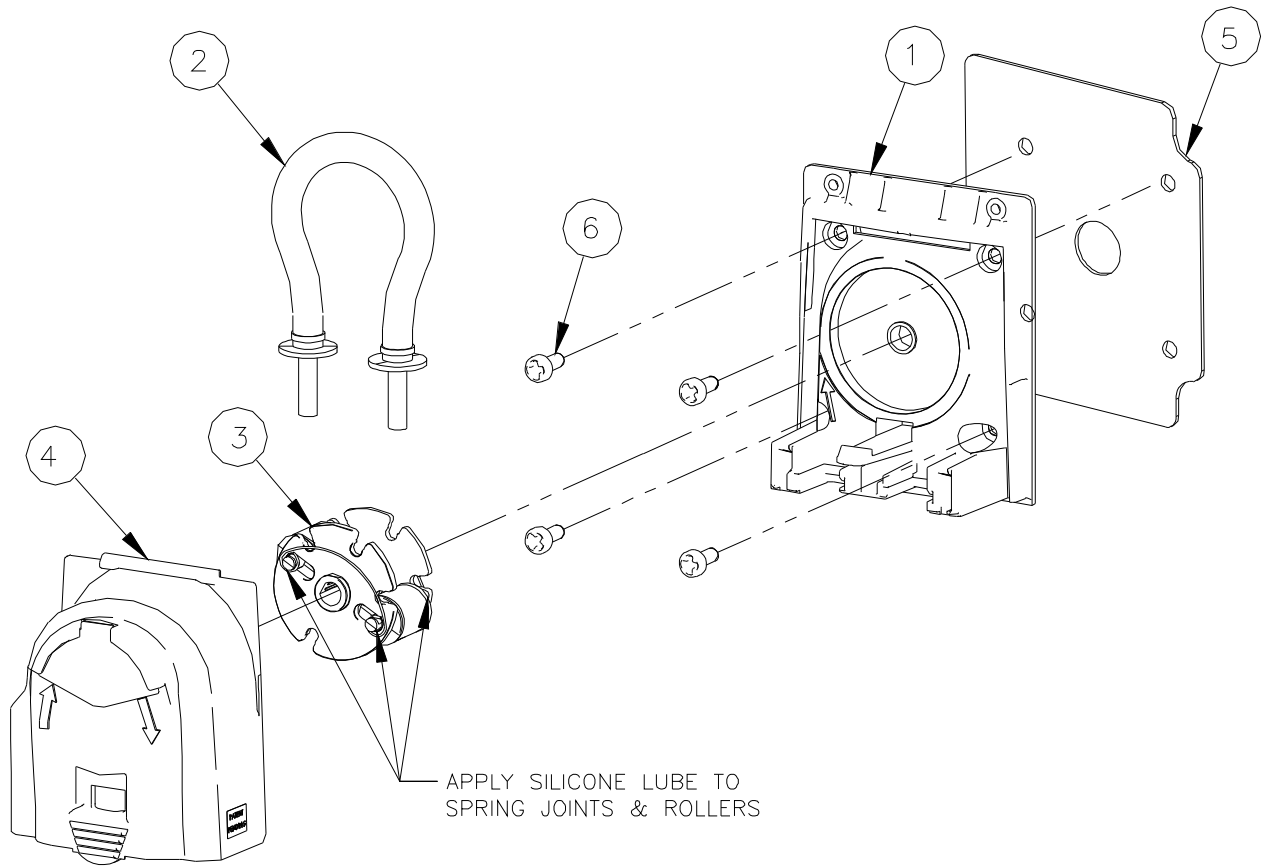

<b>REPLACEMENT PARTS</b>			
<b>NO.</b>	<b>DEMA PART NO.</b>	<b>DESCRIPTION</b>	<b>QTY.</b>
1	81-128-2	Pump Base	1
2	81-177-1	Squeeze Tube (includes plastic connectors)	1
3	81-172-1	Roller Assembly	1
4	81-174-1	Pump Cover	1
5	81-63-1	Mounting Plate	1
6	44-124-2	Screw	4
1oz.	81-17-1	Silicone Lube (not shown)	

# DEMA 259B DRAIN MASTER Jr. INSTALLATION INSTRUCTION SHEET

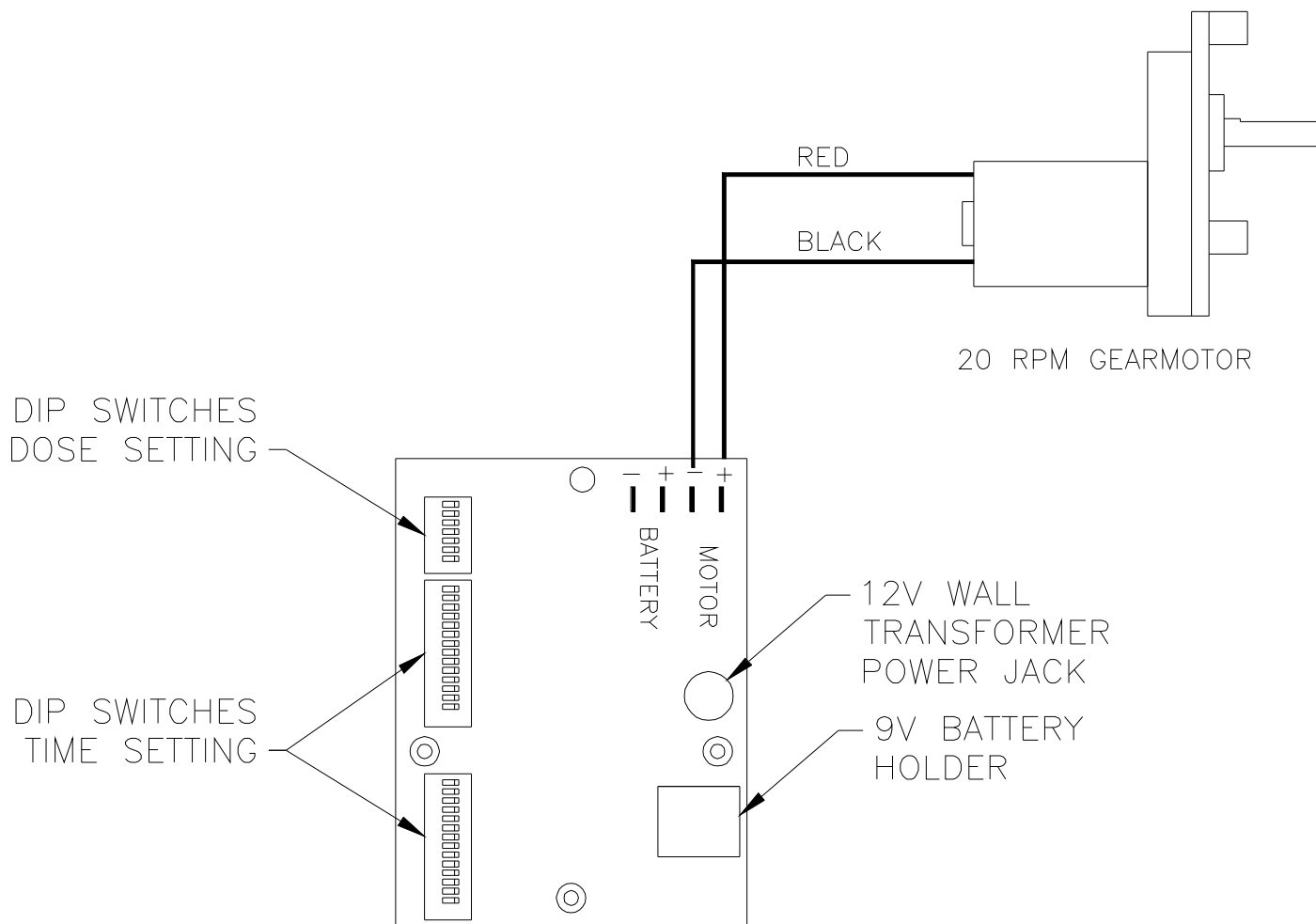

## WIRING SCHEMATIC

### **Warranty**

DEMA products are warranted against defective material and workmanship under normal use and service for one year from the date of manufacture. This limited warranty does not apply to any products, which have a normal life shorter than one year or failure and damage caused by chemicals, corrosion, improper voltage supply, physical abuse, or misapplication. Rubber and synthetic rubber parts such as “O” rings, diaphragms, squeeze tubing and gaskets are considered expendable and are not covered under warranty. This warranty is extended only to the original buyer of DEMA products. If products are altered or repaired without prior approval of DEMA, this warranty is void.

### **Return Policy**

No merchandise may be returned for credit without the written permission of DEMA Engineering Company. A return merchandise authorization (RMA) number is required in advance of return.