

**WATCH GUARD
INSTALLATION INSTRUCTIONS
MODEL 437PN**

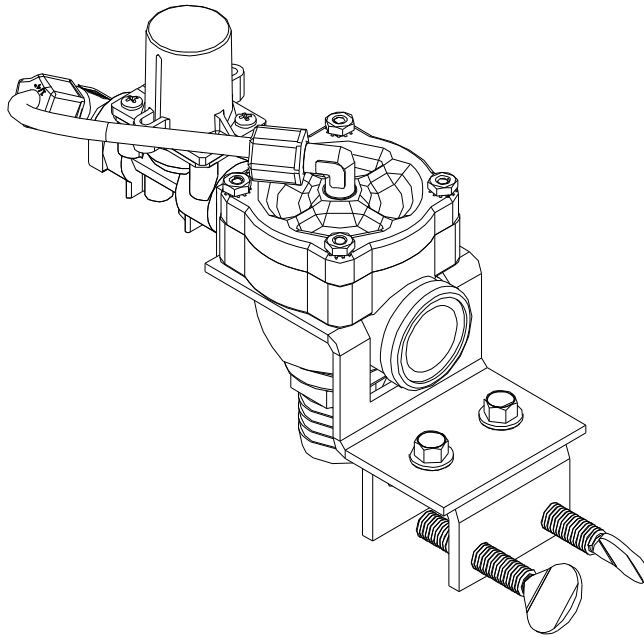

Overview

The 437PN series float valves are designed for high volume and high flow applications, to maintain a desired reservoir water level.

Warnings



ALL ELECTRICAL POWER MUST BE TURNED OFF TO THE DISPENSER AND TO THE APPLIED MACHINE.



All installations must conform to local plumbing codes and use approved backflow prevention devices. A pressure indicating tee is to be installed with existing faucets according to local plumbing codes in the state of Wisconsin and any other state that requires the use of a pressure indicating tee.



ALWAYS WEAR PROTECTIVE CLOTHING AND EYEWEAR WHEN WORKING WITH CHEMICAL PRODUCTS.

Specifications

Packing List

- A. Valve Assembly with Brackets
- B. Float and chain
- C. Instruction sheet

Operational Requirements

- 150 PSI. Max./ 15 PSI. Min. Pressure
- 120 F Max./33 F Min. Temperature
- 64 GPM Max. Flow Rate @ 50 PSI.

Parts list

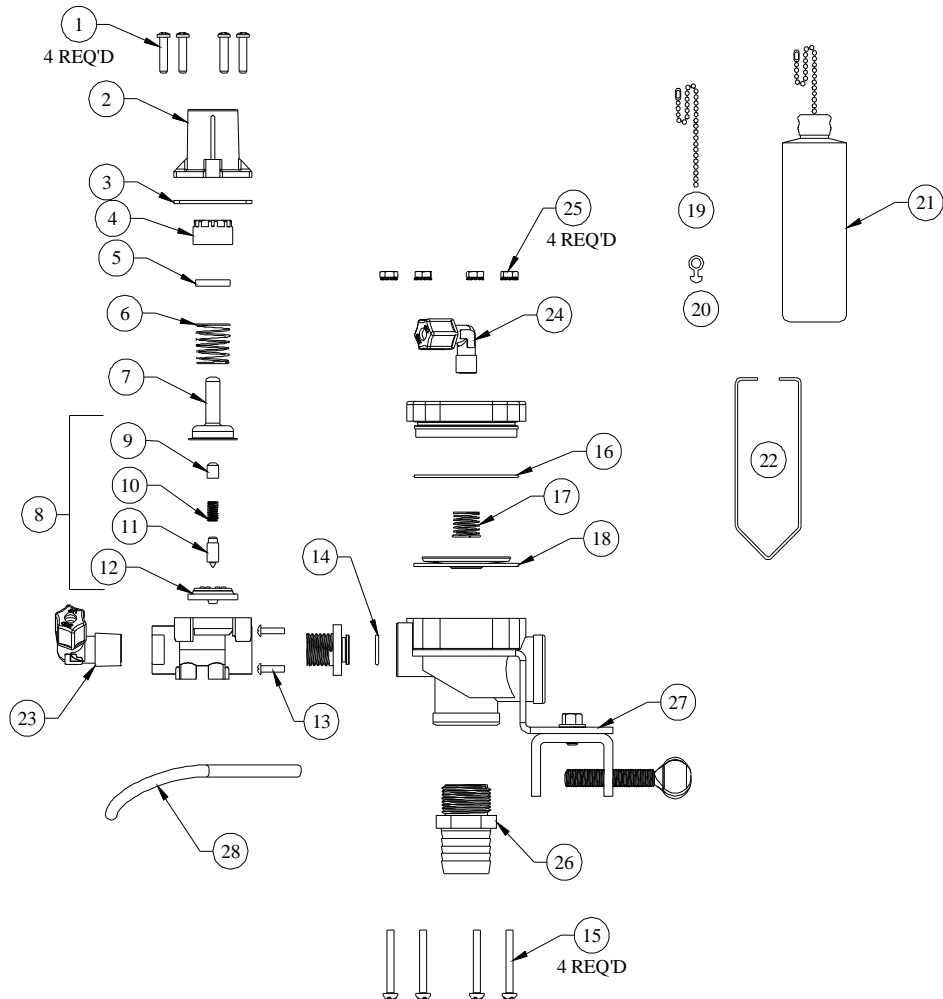

NO.	PART NO.	DESCRIPTION
1	44-116-1	Valve Cover Screw (4 Req'd)
2	35-44	Magnet Cover
3	35-37	Flange
4	35-43	Magnet Holder
5	63-35	Magnet
6	35-33	Magnet Spring
7	41-7-25	Enclosing Tube
8	63-87	Valve Repair Kit
9	63-37	Spacer
10	41-1-8	Kick-off Spring
11	63-38	Plunger
12	41-15-10	Diaphragm
13	58-60	Machine Screws (2 Req'd)
14	41-5-8	O-Ring
15	36-15-1	Valve Cover Screws (4Req'd)

NO.	PART NO.	DESCRIPTION
16	66-9	O-Ring
17	36-4	Closing Spring
18	36-23	Diaphragm Assembly
19	34-17	16" Chain W/Connector
20	35-12	Float Hanger Clip
21	35-18	Float Assembly
22	35-42	Float Hanger Wire
23		3/8" X 1/4" Compression Fitting
24		1/8" X 1/4" Compression Fitting
25		Hex Nut
26		3/4" X 1" Barb
27		Bracket
28		LDPE Tube
29		Hose, Braided (Shown on Pg.3)

Installation

A. Valve Assembly:

Mount the valve to the tank wall by tightening the two thumbscrews as shown in figure #1 or #3. We recommend using the additional leverage of pliers to firmly secure the bracket. Attach desired 3/4" NPT fitting to the water inlet. Apply pipe dope or 2-3 wraps of Teflon tape on all pipe threads. Attach hose or 3/4" pipe nipple (not provided) to the water outlet to prevent splashing. **DO NOT OVERTIGHTEN.** The outlet hose should be below the bottom of the float. The outlet hose cannot restrict travel of float as tank empties and refills.

B. Float:

Run chain through the clip on the pull wire until the top of the float is about 1 to 2 inches above the desired maximum water level (with pull wire in "up" position). Snap the bead into the clip to hold the chain in place. Excess chain may be removed, or additional chain may be added. (Fig. 2)

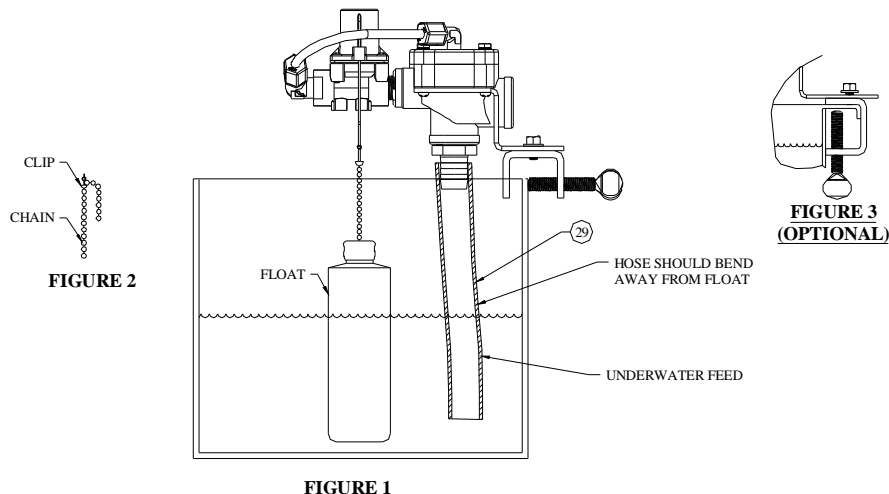

Operation

Turn on the main water valve. When the fluid level reaches about two (2) inches below the top of the float, the valve will close. When the tank level drops about four (4) inches, the valve will open. Water flow is shown in Table 1.

CV Flow Factor	GPM AT PRESSURE SHOWN				
	5 PSI	15 PSI	30 PSI	40 PSI	50 PSI
9	20	34	49	57	64

TABLE 1

Troubleshooting

CAUTION: TURN OFF WATER SUPPLY BEFORE SERVICING.

If valve fails to open, check that water supply does not exceed 150 psi. If valve fails to open or close, check that the wire moves freely up & down and that a "click" can be heard when the wire is pulled and released, indicating that the magnet is activating the plunger properly. To inspect internal parts, remove magnet housing and carefully pull off the enclosing tube so as not to drop the plunger, kick-off spring and spacer. Check for dirt or damage impeding plunger and kick-off spring movement. Inspect the diaphragm, making sure two small pin holes (bleed holes) in the diaphragm are clear to allow the valve to close.

CAUTION: WHEN SERVICING UNIT, BE SURE THAT REPLACEMENT PARTS HAVE BEEN INSTALLED ACCORDING TO DRAWING.

Warranty

RETURNS: NO MERCHANDISE MAY BE RETURNED FOR CREDIT WITHOUT DEMA'S WRITTEN PERMISSION. RETURN MERCHANDISE AUTHORIZATION NUMBER REQUIRED IN ADVANCE OF RETURN.

WARRANTY: DEMA products are warranted against defective material and workmanship under normal use and service for one year from the date of manufacture. This limited warranty does not apply to any products which have a normal life shorter than one year or failure and damage caused by chemicals, corrosion, improper voltage supply, physical abuse, or misapplication. Rubber and synthetic rubber parts such as "o"-rings, diaphragms, squeeze tubing and gaskets are considered expendable and are not covered under warranty. This warranty is extended only to the original buyer of DEMA products. If products are altered or repaired without prior approval of DEMA, this warranty will be void.

Defective units or parts should be returned to the factory with transportation prepaid. If inspection shows them to be defective, they will be repaired or replaced without charge, F.O.B. factory. DEMA assumes no liability for damages. Return merchandise authorization number, to return units for repair or replacement, must be granted in advance of return.