

DEMAMaster Nitro Express Ware Wash Chemical Dispenser

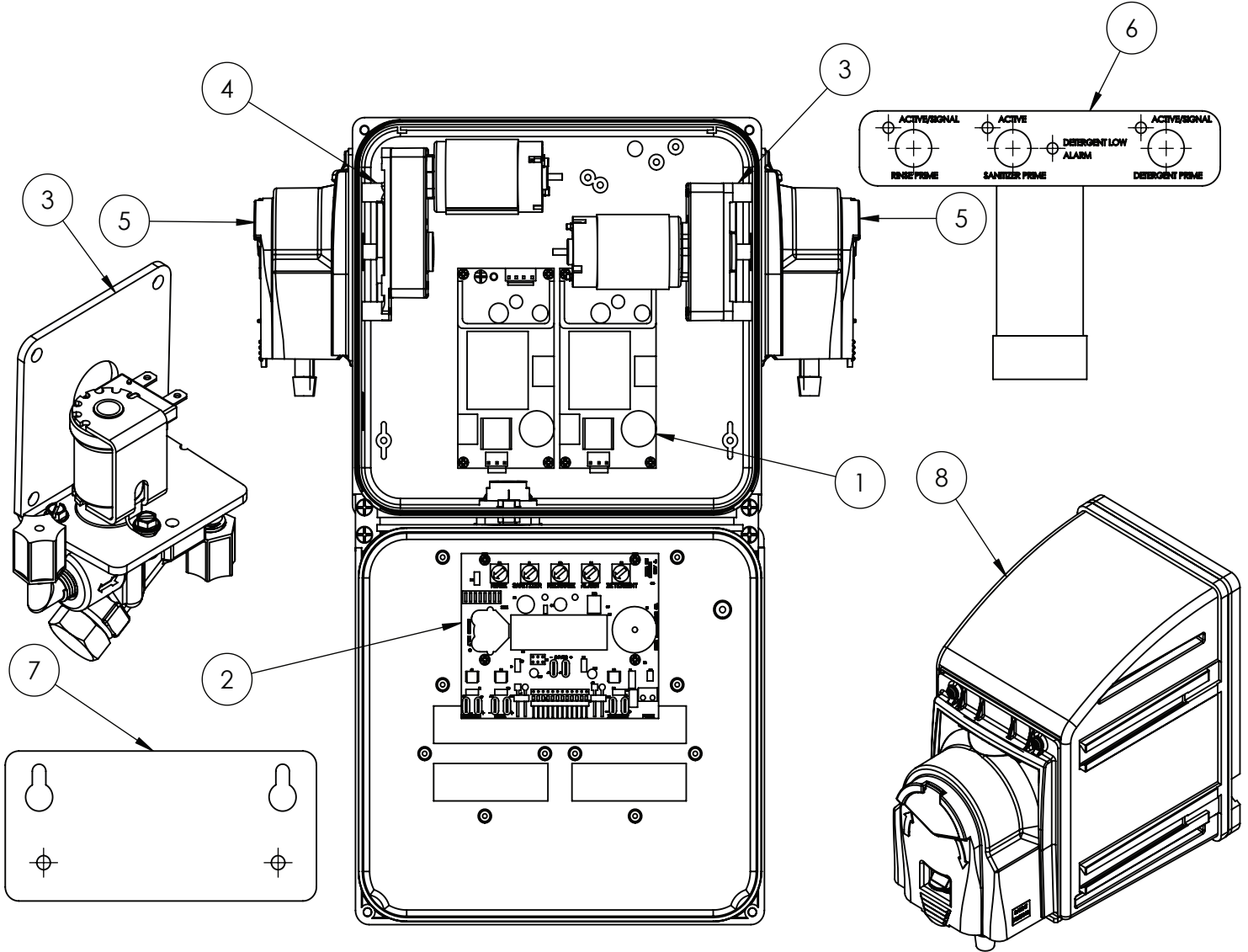

NO.	KIT NO.	DESCRIPTION
1	81.316.1	DM NITRO EXPRESS POWER SUPPLY REPLACEMENT KIT (TRIGGER OUTPUT TRANSFORMER)
2	81.316.3	CONTROL BOARD DM NITRO EXPRESS WITH SANITIZER (3 PRODUCT)
3	81.118.29.1	PUMP – 2 SPRING ROLLER, 60 RPM MOTOR ¼" ID KIT
	80.59.60MK	60 RPM DETERGENT MOTOR
	44.123.14B	DM NITRO EXPRESS DETERGENT VALVE REPLACEMENT
4	81.118.29.2	PUMP – 3 ROLLER FIXED, 15 RPM MOTOR 1/8" ID KIT
	80.59.15MK	15 RPM RINSE MOTOR
5	81.118.15	DETERGENT PUMP KIT – 2 ROLLER SPRING LOADED
	81.118.16	RINSE PUMP HEAD KIT – 3 ROLLER FIXED
6	L1115	MEMBRANE LABEL
7	81.1	MOUNTING BRACKET
8	81.118.15WM	DM NITRO EXPRESS SANITIZER PUMP W/ WALL BRACKET (BRACKET NOT SHOWN)