

# DEMA MODEL 606T-WI SELECT-O-SPRAY

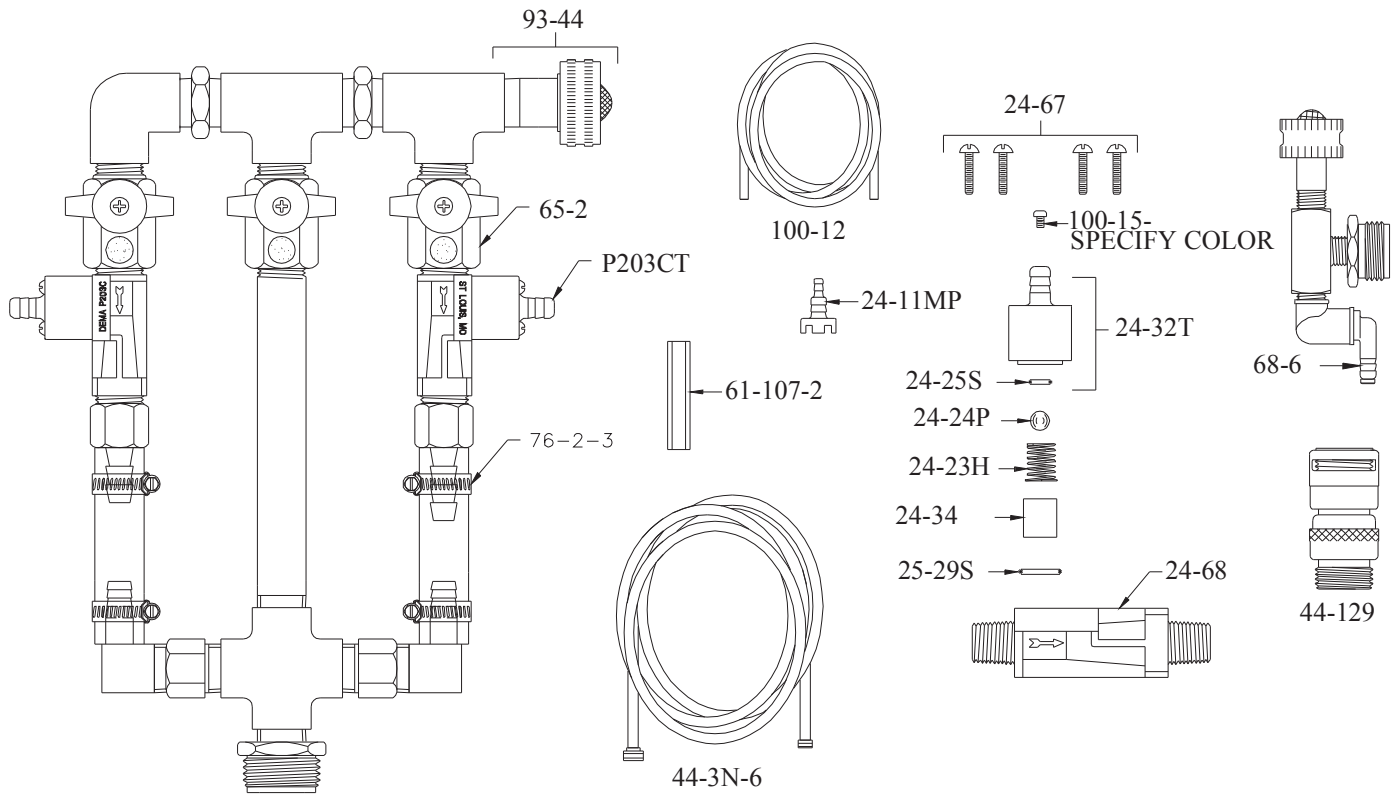

## OPTIONAL ACCESSORIES

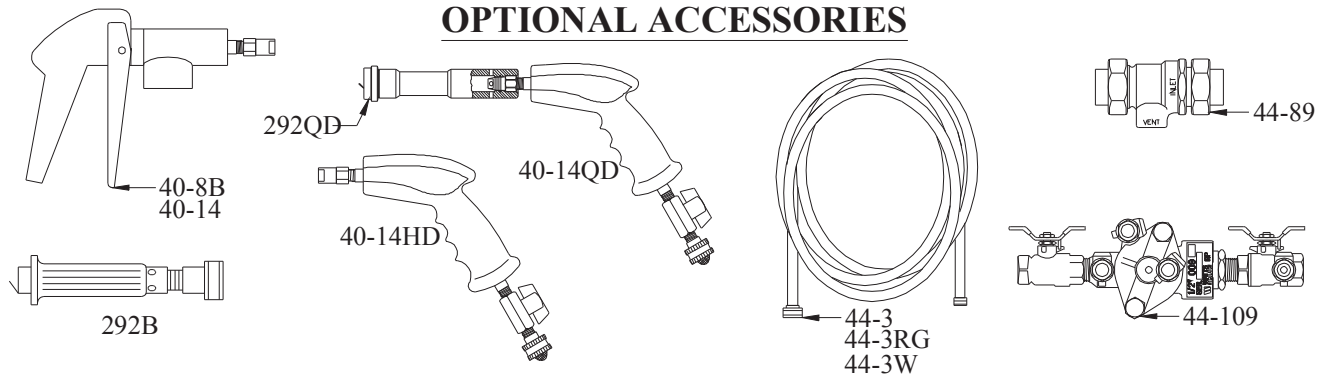

PART NO.	DESCRIPTION
24-11MP	FOOT STRAINER
24-23H	CHECK VALVE SPRING
24-24P	CHECK VALVE BALL
24-25S	CHECK VALVE O-RING
24-32T	METERING KNOB
24-34	CHECK VALVE CORE
24-67	SCREW (1" LG 4-REQD.)
24-68	VALVE BODY
25-29S	O-RING
44-3N-6	NYLON BRAIDED INLET HOSE
44-129	BACKFLOW PREVENTER
61-107-2	CERAMIC WEIGHT
65-2	BALL VALVE
76-2-3	HOSE CLAMP
68-6	PRESSURE INDICATING TEE
93-44	WATER INLET

100-12	VINYL TUBING 1/4ID X 8'LG
100-15-	METERING TIP SPECIFY COLOR
100-38	STRAINER WASHER
P203CT	INJECTOR
OPTIONAL ACCESSORIES	
44-3	HOSE (BLACK) 25' X 1/2 ID
44-3RG	HOSE (RED) SPRING GARD 25' X 1/2 ID
44-3W	HOSE (WHITE) 25' X 1/2 ID
40-8B	SPRAY GUN
40-14	SPRAY GUN
40-14HD	HEAVY DUTY SPRAY GUN
40-14QD	HEAVY DUTY SPRAY GUN W/ DISCONNECT
44-89	BACKFLOW PREVENTER (A.S.S.E. 1012)
44-109	BACKFLOW PREVENTER (A.S.S.E. 1013)
292B	FOAM WAND
292QD	FOAM WAND W/ DISCONNECT