

DEMA SURE-MEASURE DISPENSER MODEL 301B-SY

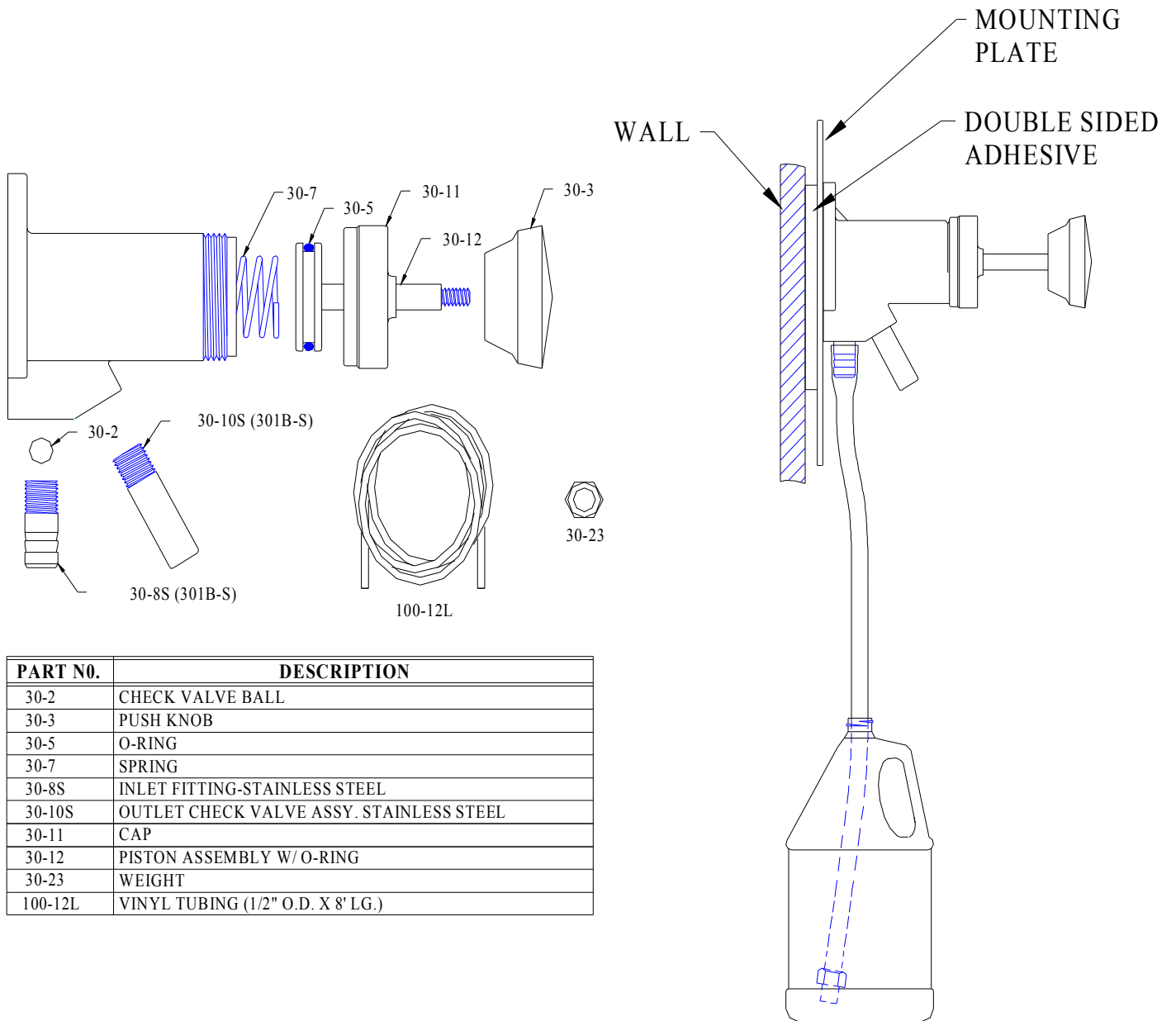

| PART NO. | DESCRIPTION |
|----------|--|
| 30-2 | CHECK VALVE BALL |
| 30-3 | PUSH KNOB |
| 30-5 | O-RING |
| 30-7 | SPRING |
| 30-8S | INLET FITTING-STAINLESS STEEL |
| 30-10S | OUTLET CHECK VALVE ASSY. STAINLESS STEEL |
| 30-11 | CAP |
| 30-12 | PISTON ASSEMBLY W/ O-RING |
| 30-23 | WEIGHT |
| 100-12L | VINYL TUBING (1/2" O.D. X 8' LG.) |