

DEMA MODEL 258D AND 258T DRAIN AND TRASHMASTER™

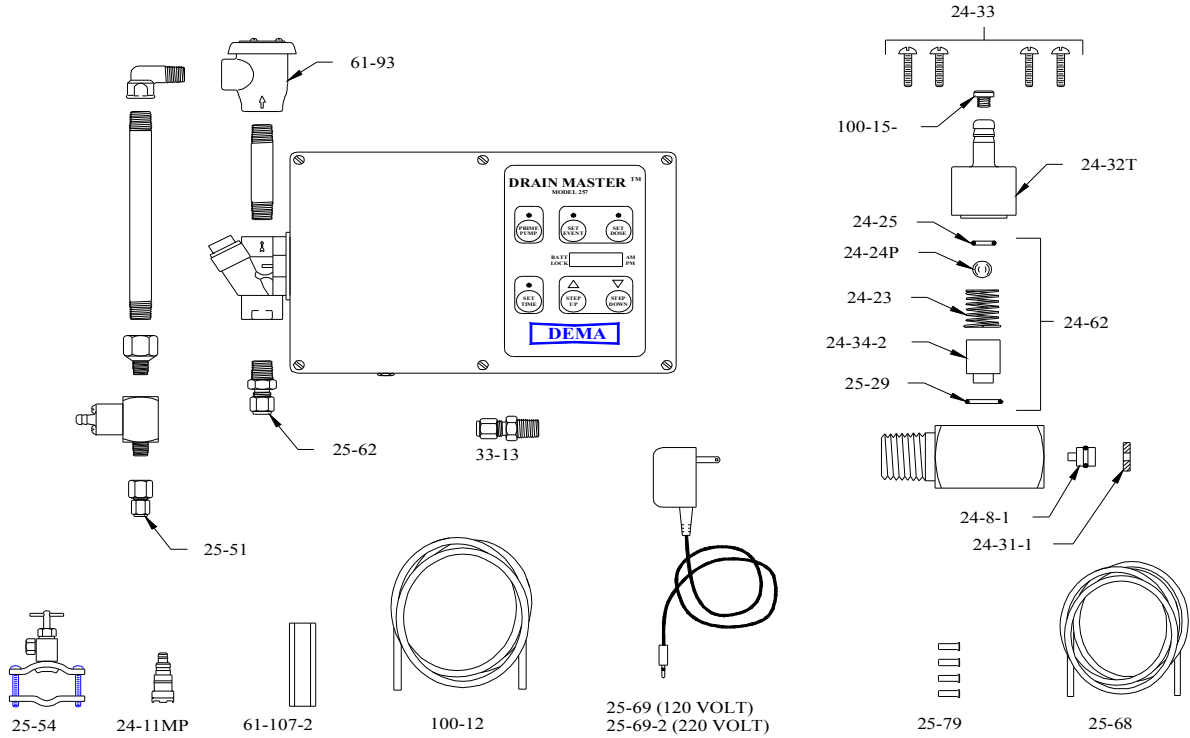

PART NO.	DESCRIPTION
24-8-1	WATER NOZZLE
24-11MP	FOOT STRAINER
24-23	CHECK VALVE SPRING
24-24P	CHECK VALVE BALL
24-25	CHECK VALVE O-RING
24-31-1	BACK-UP WASHER
24-32T	PLASTIC KNOB
24-33	SCREW (4-REQD)
24-34-2	CHECK VALVE CORE
24-62	CHECK VALVE REPAIR KIT
25-29	METERING KNOB O-RING
25-51	COMPRESSION FITTING
25-54	SADDLE VALVE
25-62	COMPRESSION FITTING 1/4"
25-68	SUPPLY TUBE (20 FT. LG.)

PART NO.	DESCRIPTION
25-69	A.C. ADAPTER (120 VOLT)
25-69-2	A.C. ADAPTER (220 VOLT)
25-79	TUBE INSERT (4-PCS)
33-13	COMPRESSION FITTING
61-93	VACUUM BREAKER
61-107-2	CERAMIC WEIGHT
100-12	VINYL TUBING (8 FT. LG.)
100-15	METERING TIP (SPECIFY COLOR)
200-CT	INJECTOR COMPLETE

ACCESSORIES FOR TRASHMASTER ONLY NOT SHOWN

25-80	SPRAY NOZZLE
25-81	MOUNTING BRACKET
25-82	#8 SHEET METAL SCREW

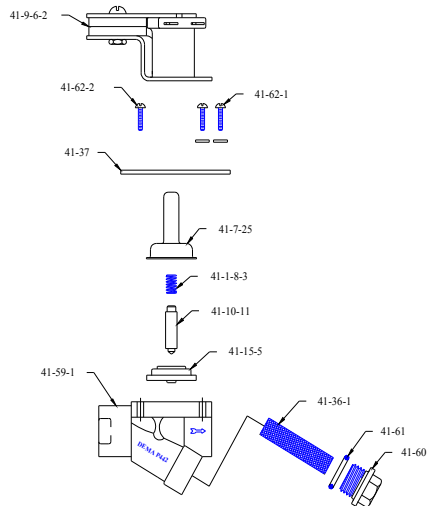

PART NO.	DESCRIPTION
26-71	WASHER (3-REQD)
41-1-8-3	KICK-OFF SPRING
41-7-25	ENCLOSING TUBE (STAINLESS)
41-9-6-2	SOLENOID COIL
41-10-11	PLUNGER
41-15-5	DIAPHRAGM
41-36-1	STRAINER SCREEN
41-37	FLANGE
41-59-1	VALVE BODY
41-60	SCREEN CAP
41-61	O-RING SEAL
41-62-1	SCREW #8-18 X 1 1/2 LG. (2 REQD.)
41-62-2	SCREW #8-18 X 3/8 LG. (1 REQD.)