

DEMA MODEL 162HDM-2 DRUM MOUNT INJECTOR

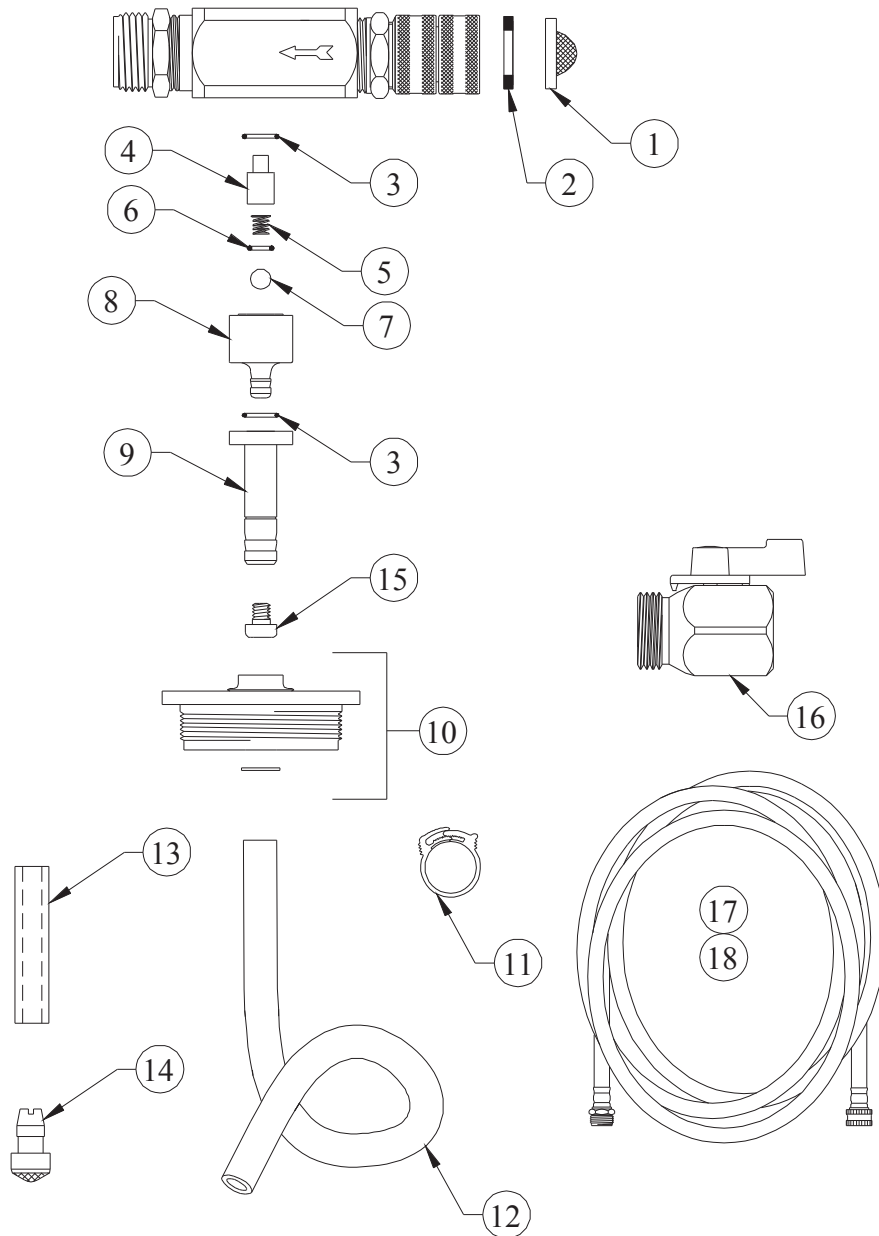

NO.	PART NO.	DESCRIPTION
1	100-38	Strainer Washer
2	150-6	Rubber Washer
3	25-29	O-Ring
4	23-34-1	Core
5	24-23	Spring
6	24-25	O-Ring
7	24-24S	¼" Ball
8	24-32T	Metering Knob
9	44-65	Drum Nipple Assy.
10	16-7	Bung Cap & Retainer Ring
11	16-9-2	Tubing Clamp, Plastic

NO.	PART NO.	DESCRIPTION
12	100-12L-3	3/8" I.D. X 4 Foot Vinyl Tubing
13	61-107	Ceramic Weight – ½" I.D.
14	24-11L	Foot Strainer – S.S.

ACCESSORIES

NO.	PART NO.	DESCRIPTION
15	61-9K	Metering Tip Kit (13 Sizes)
16	90-15	Ball Valve – GHT
17	44-3	Rubber Hose, ½" I.D. X 25 FT.
18	44-3-6	Rubber Hose, ½" I.D. X 6 FT.