

# DRUM MOUNTED PROPORTIONER DEMA MODEL 162-3

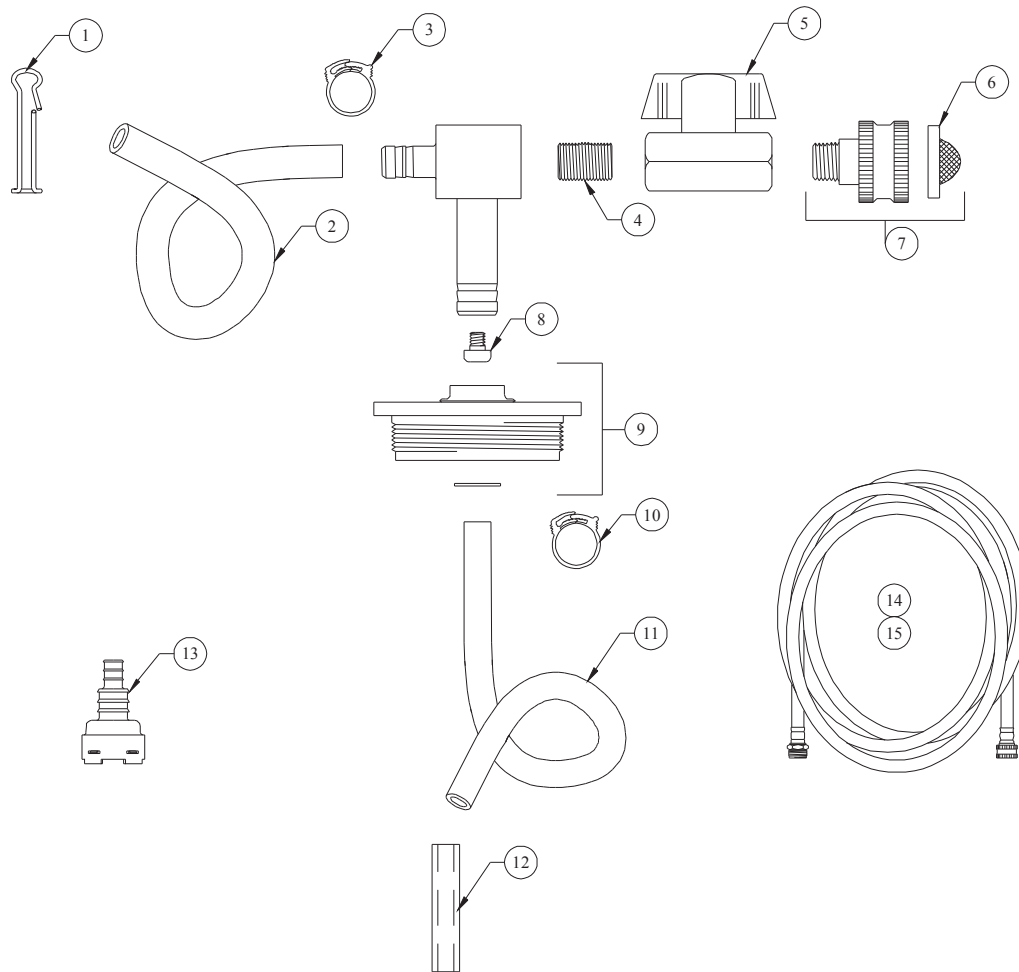

NO.	PART NO.	DESCRIPTION
1	16-4-3	Outlet Tubing Hanger
2	16-3	Outlet Tubing, 11/16" OD x 3' Lg.
3	16-9	Tubing Clamp – Plastic (1/2" ID Tubing)
4	16-8	1/4" NPT Pipe Nipple
5	16-11	1/4" NPT Ball Valve
6	100-38	Strainer Washer
7	16-1	Coupling & Strainer Washer
8	61-9K	Metering Tip Kit

NO.	PART NO.	DESCRIPTION
9	16-7	Bung Top & Retainer Ring
10	16-9-2	Tubing Clamp – Plastic (3/8" ID Tubing)
11	100-12LS	Supply Tubing – 3/8" ID x 3 1/2' Lg.
12	61-107	Ceramic Weight for 3/8" ID Tubing
13	100-16E	Diaphragm Foot Valve - EPDM

## ACCESSORIES

NO.	PART NO.	DESCRIPTION
14	44-3	Rubber Hose – 1/2" ID x 25'
15	44-3-6	Rubber Hose – 1/2" ID x 6'