

DEMA MODEL 692T FOAM STATION I

INSTALLATION INSTRUCTION

1. PARTS CHECKLIST:

ITEM	DESCRIPTION	QTY.
A.	Foam Station Assembly	1
B.	#10 Screw & Anchor Kit Set (Total: 4 Screws & 4 Anchors)	1
C.	Ceramic Weight	1
D.	¼" ID Tubing & Foot Valve Assembly	1
E.	Metering Tip Kit (P/N 61-9K)	1
F.	Label Card	1

2. INSTALLATION:

This product is designed only to be used as described in this instruction sheet. Adhere to all warnings and cautions identified in this document.



WARNING: Installations must conform to all local and national plumbing codes and use approved backflow prevention and pressure relief devices where required.

ALWAYS DISCONNECT DISPENSER FROM WATER SOURCE WHEN DISPENSER IS NOT IN USE.



Always read SDS for all chemicals used and follow personal protective guidelines.

A. Mounting and Water Supply:

Locate mounting holes on a permanent vertical wall. Drill all holes into the drywall using a ¼" diameter bit for use with the included #10 screw and anchor set. (If mounting unit to wood and you do not plan to use the included anchors, drill 1/8" diameter holes.) Insert the anchors into drilled holes and hammer them into the wall until they are flush with face of wall. Assemble the #10 screws with a phillip screwdriver into the anchors for the keyhole slots so the screw heads are sticking out of the wall approximately ½". Mount the unit by inserting the screw heads through the keyhole slots and tightening the screws. Secure the unit by inserting screws into the lower 2 holes.

The water inlet is equipped with a female garden hose fitting. The fitting may be removed to permit direct connection to 3/8" NPT pipe. **Note: Apply pipe dope, hand tighten, and then turn 1-1/2 times with a wrench. DO NOT OVER TIGHTEN.**

WARNING: Do not use Teflon tape to seal internal plastic threads as the extra thickness of the tape may cause the plastic to crack. Use non-welding liquid sealant instead.

WARNING: Water supply should not exceed 125 psi and water temperature must not exceed 150°F.

B. Outlet Connection:

Connect the discharge hose to the garden hose fitting. **NOTE: Be sure to clamp garden hose onto wall approximately 1 ft. below the unit, (Clamps, screws, & anchors are not supplied.)** Attach shut-off valve to the discharge end of the hose. See Table 1 for hose limitations.

TABLE 1: Outlet Garden Hose Connection

GARDEN HOSE SIZE AND LENGTH	MIN. PRESSURES	
	WATER	AIR
25' OF ¾" ID	40 PSI	40 PSI
50' OF ¾" ID	50 PSI	40 PSI
25' OF ½" ID	60 PSI	40 PSI

DEMA MODEL 692T FOAM STATION I

INSTALLATION INSTRUCTION

C. Chemical Supply:

WARNING: USE CARE WHEN HANDLING HAZARDOUS CHEMICALS.

Place the chemical container in a convenient location not more than six feet below the Foam Station. (Greater lifts will reduce injection capabilities). The top of the container should not be above the Foam Station. Cut the vinyl tube to any convenient length that will allow the tubing to reach the bottom of the container. Drop the tubing end with the strainer into the chemical container. Push the other tubing end over the chemical inlet barb located on the side of the Foam Station.

3. CHEMICAL ADJUSTMENT:

The chemical feed rate is controlled by metering tips screwed into the barb on the side of the Foam Station. The feed rates can be changed using different metering tips. To select the proper metering tip size for the desired dilution ratio, refer to Table 2.

TABLE 2

Metering Tip Color	Injection Rate for Viscosities Shown							
	1 cps		75 cps		200 cps		500 cps	
	Oz/Gal	Ratio	Oz/Gal	Ratio	Oz/Gal	Ratio	Oz/Gal	Ratio
Clear	0.84	152-1	0.65	197-1	0.45	284-1	0.30	427-1
Purple	1.35	95-1	1.10	116-1	0.90	142-1	0.60	213-1
Yellow	2.40	53-1	2.00	64-1	1.50	85-1	1.10	116-1
Green	4.20	30-1	3.40	38-1	2.65	48-1	2.10	61-1
Pink	5.25	24-1	4.50	28-1	3.45	37-1	2.60	49-1
Turquoise	9.40	14-1	7.25	18-1	5.45	23-1	3.70	35-1
Black	11.75	11-1	8.80	15-1	6.35	20-1	4.20	30-1
Gray	14.50	9-1	10.80	12-1	7.75	17-1	4.75	27-1
Red	18.00	7-1	13.20	10-1	8.30	15-1	5.00	26-1
Blue	20.60	6-1	14.70	9-1	8.65	14.8-1	5.20	25-1
Brown	24.10	5-1	16.15	8-1	9.30	14-1	5.50	23-1
White	27.50	4.7-1	17.80	7-1	9.70	13-1	5.70	22-1
Orange	30.00	4.3-1	18.50	6.9-1	10.10	12.7-1	5.85	21.9-1
Light Blue	32.00	4-1	18.90	6.8-1	10.20	12.5-1	6.00	21-1
Tan	32.50	3.9-1	19.25	6.6-1	10.40	12.3-1	6.25	20.5-1
None	34.25	3.7-1	20.45	6-1	10.60	12-1	6.50	20-1

All induction rates are based on 40 psi water pressure and 40 psi air pressure.

4. OPERATION:

The 692T Foam Station permits the operator to select a chemical to foam (left hand lever), or a clear water rinse (middle lever) by opening and closing the appropriate valve with its lever. **ONLY ONE VALVE SHOULD BE OPEN AT ANY TIME.** If two valves are opened simultaneously, the injector will not draw chemical.

NOTE: When using the spray wand, make sure that the shut-off valve at the end of the hose is in the fully open position in order to draw chemical product.

To Foam:

First: Open the left hand lever all the way. Water rushing through the foamer will draw up soap and send soapy water through the hose.

Next: Pull out on the air regulator knob above the air gage. Set the air regulator to 40psi. Open the air valve on the left side of the 692T. Adjust the air regulator upwards gradually until you obtain the thickness of foam you desire. Push the air regulator

DEMA MODEL 692T FOAM STATION I

INSTALLATION INSTRUCTION

knob back in to lock the setting in place. This operation must be repeated in the same order each time the 692T is shut down and restarted (water first then gradually build up air pressure).

TABLE 3: Water Flow & Air Flow Setting

	PRESSURE (PSI)			
	40	50	60	80
WATER FLOW (GPM)	1.4	1.6	1.7	2.1
AIR FLOW (SCFM)	3.5	4.2	4.8	6.1

5. SERVICING:

PROBLEM:

Unit will not draw or stops drawing chemical
 Poor foam quality
 Foam surges
 Foam output is too wet
 Foam output is too dry
 Water is flowing into chemical container
 Foam does not clean adequately

SEE SITUATION:

1, 2, 3, 5, 6, 10, 11, 12, 13, 15, 16, 17
 1, 2, 3, 5, 6, 10, 11, 12, 13, 15, 16
 1, 2, 3, 4, 5, 6, 8, 9, 10, 11, 12, 13, 15, 16
 1, 3, 4, 5, 6, 7, 8, 9, 10, 11, 13, 16
 2
 12
 4, 8, 11, 14

POSSIBLE SITUATIONS

Situation	Cause	Solution
1	Chemical tube not immersed in chemical or chemical depleted.	Immerse tube in chemical or replace.
2	Air pressure is too high for water.	Adjust air regulator down.
3	Water pressure is too low.	At least 30 psi is required. Increase if possible, or decrease air pressure.
4	Chemical to water ratio is too low.	Change metering tip to one that is larger.
5	Foam hose is kinked.	Straighten hose.
6	Foam hose is too long or wrong size.	See Table 1.
7	Air supply is inadequate.	Increase air pressure by regulating up.
8	Detergent is wrong.	Use a more effective detergent, and be sure that product is recommended for foaming.
9	Using an oiler on the airline may deteriorate the quality of the foam.	Use only clean, dry air.
10	Holes or cuts are in chemical inlet tube.	Replace the tube.
11	Strainer and/or metering tip are blocked.	Remove, clean or replace.
12	Solution check valve is not working.	Remove, clean or replace.
13	Air regulator is not working.	Remove, clean or replace.
14	Soil has hardened on surface.	Reapplication may be necessary. Be sure to rinse foam off before it dries.
15	Rust or build-up is clogging the foamer aspirator.	Disconnect water from unit and remove injector from unit. Visually inspect. Remove blockage.
16	Water scale or chemical build-up may have formed in the water jets.	Place the chemical tube in descaling acid and completely open the shut-off valve. Let unit run until the chemical tube is filled with acid, then close shut-off valve and water supply. Elevate the chemical tubing and outlet hose until acid has had enough time to descale. Repeat if necessary. For severe cases, disassemble unit and soak foamer body in descaling acid.
17	More than one valve is open.	Close the rinse valve.

DEMA MODEL 692T FOAM STATION I

INSTALLATION INSTRUCTION

Return Policy

No merchandise may be returned for credit without DEMA Engineering Company's written permission. Return Merchandise Authorization (RMA) number required in advance of return.

Warranty

DEMA products are warranted against defective material and workmanship under normal use and service for one year from the date of manufacture. This limited warranty does not apply to any products which have a normal life shorter than one year or failure and damage caused by chemicals, corrosion, improper voltage supply, physical abuse or misapplication. Rubber and synthetic rubber parts such as "O"-rings, diaphragms, squeeze tubing and gaskets are considered expendable and are not covered under warranty. This warranty is extended only to the original buyer of DEMA products. If products are altered or repaired without prior approval of DEMA, this warranty will be void.

Defective units or parts should be returned to the factory with transportation prepaid. If inspection shows them to be defective, they will be repaired or replaced without charge. F.O.B. factory DEMA assumes no liability for damages. Return merchandise authorization number to return units for repair or replacement must be granted in advance of return.

DEMA MODEL 692T FOAM STATION I

INSTALLATION INSTRUCTION

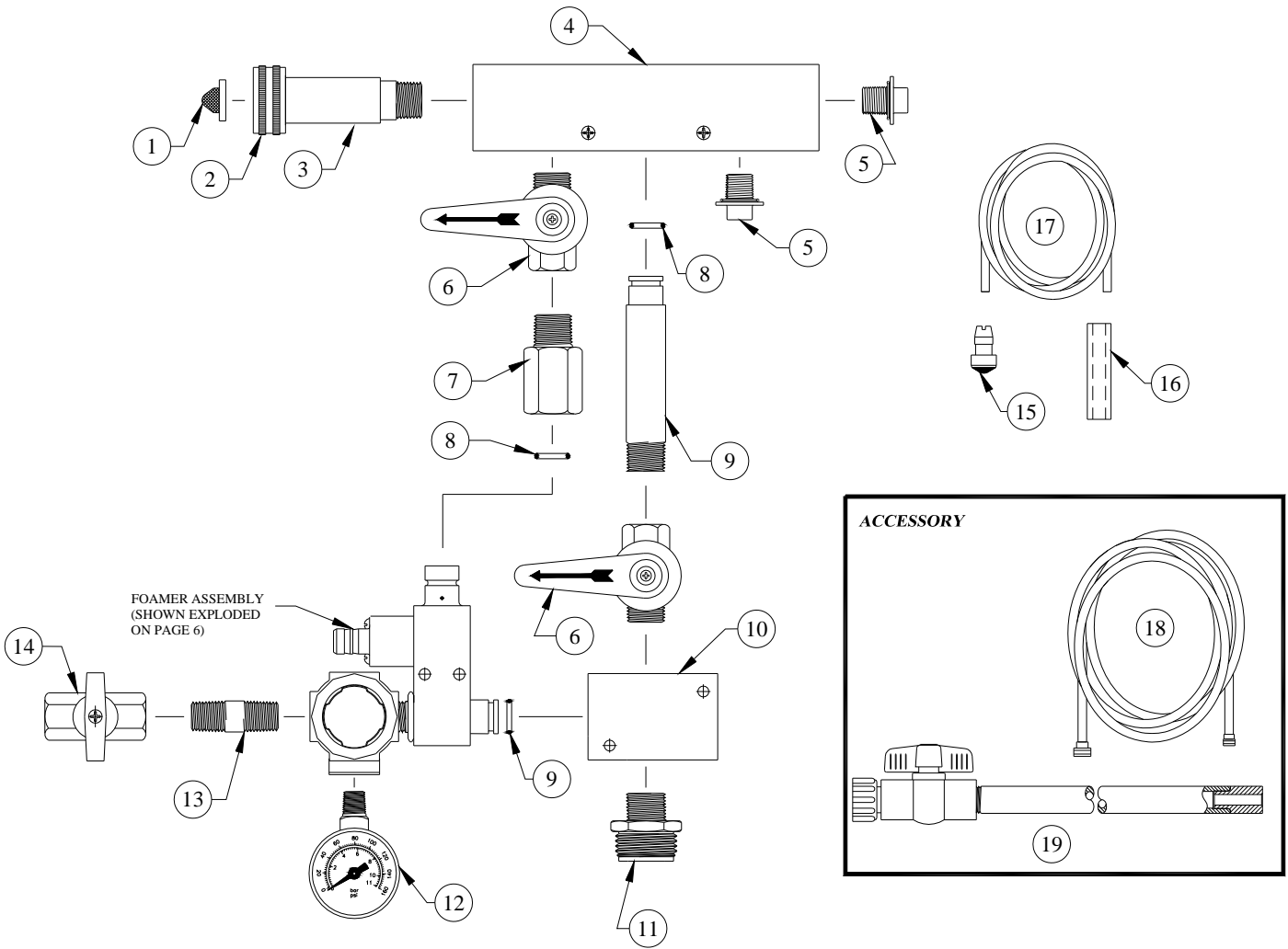

NO.	PART NO.	DESCRIPTION
1	100-38	Strainer Washer
2	65-10	Swivel Coupling
3	65-14	Swivel Adapter
4	69-8-2	Top Manifold
5	66-153	Pipe Plug & O-Ring Assy.
6	99-8-2	Valve Knob
7	69-2	Adapter
8	30-5-14	O-Ring (EP)
9	58-83-1	Pipe Adapter
10	69-7-1	Bottom Manifold
11	65-18-1	Outlet Fitting
12	93-2	Pressure Gauge
13	25-137-12	1/4" NPT Nipple X 1 1/2" Lg.

NO.	PART NO.	DESCRIPTION
14	16-11	1/4" NPT Ball Valve
15	24-11L	Foot Strainer
16	61-107	Ceramic Weight (3/8" ID Tubing)
17	100-12L	Vinyl Tubing (3/8" ID X 8 Ft. Long)

ACCESSORIES		
NO.	PART NO.	DESCRIPTION
18	93-14	3/4" ID X 25' Lg. Outlet Hose
19	93-18	Plastic Foam Wand

DEMA MODEL 692T FOAM STATION I

INSTALLATION INSTRUCTION

FOAMER ASSEMBLY BREAKDOWN

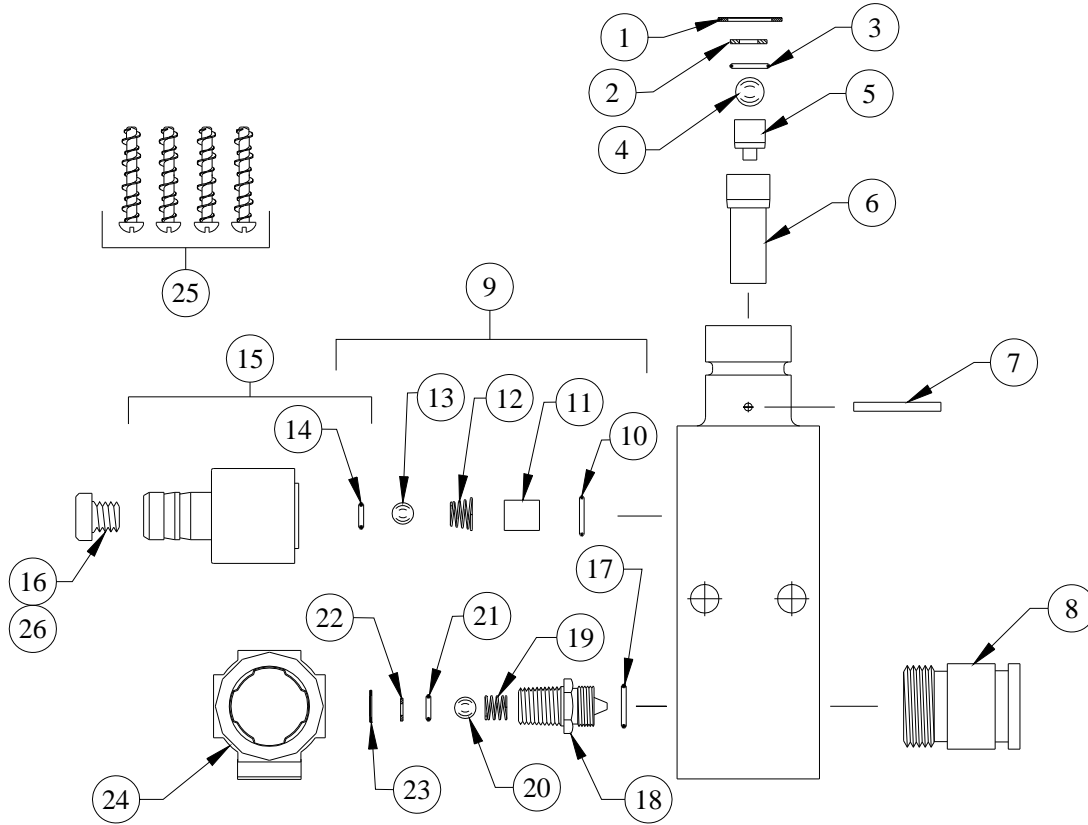

NO.	PART NO.	DESCRIPTION
1	29-18-2	5/16 Internal Snap Ring
2	29-17-2	Washer (S.S.) –Air Hose
3	29-7	O-Ring (Viton)
4	29-5P	Ball 11/32” Dia.
5	29-16	Nozzle
6	29-11	Diffuser
7	29-15-2	Pin
8	69-3	Adapter
9	29-12	Check Valve Repair Kit
10	25-29V	Metering Knob O-Ring (Viton)
11	23-34-3	Check Valve Core
12	23-9-2	Check Valve Spring
13	23-10	Check Valve Ball (9/32” Dia. S.S.)
14	23-11V	Check Valve O-Ring (Viton)
15	24-59-5	Metering Knob
16	61-9	Metering Tip (Specify Color)

NO.	PART NO.	DESCRIPTION
17	30-5V-1	O-Ring (Viton)
18	2914	Air Nozzle
19	93-6-2	Air Check Valve Spring
20	26-49P	Ball 3/16” (Teflon)
21	90-35V	Air Check Valve Spring
22	29-17-3	Washer (S.S.) – Foamer inlet
23	29-18-4	7/16” Internal Snapping
24	93-1	Pressure Regulator
25	29-10	Hi Lo Screw (Req’d)

ACCESSORIES		
NO.	PART NO.	DESCRIPTION
26	61-9K	Metering Tip Kit