

SQUIRT DC

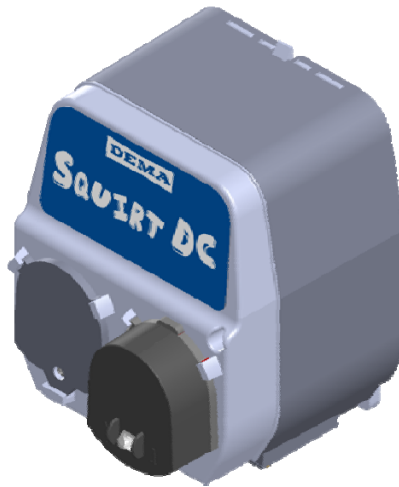

Overview

The squirt DC is a battery operated chemical dispenser with a programmable timer designed primarily for dispensing chemical into drains. Its intended use is for drain applications when a degreaser is needed in the drain regularly. The timer is programmable up to 8 events and can be set for specified time periods to run the pump.

Warnings



Installation of DEMA products must meet all applicable electrical codes and regulations established by national, city, county, parish, provincial or other agencies. It is possible that electrical codes and regulations require that a certified electrical contractor or engineer perform the electrical installation. For questions, contact a certified electrician.



ALL ELECTRICAL POWER MUST BE TURNED OFF TO THE DISPENSER AND TO THE APPLIED MACHINE.



All installations must conform to local plumbing codes and use approved backflow prevention devices. A pressure indicating tee is to be installed with existing faucets according to local plumbing codes in the state of Wisconsin and any other state that requires the use of a pressure indicating tee.



ALWAYS WEAR PROTECTIVE CLOTHING AND EYEWEAR WHEN WORKING WITH CHEMICAL PRODUCTS.

Specifications

Packing List

DEMA NO.	SQUIRT DC DRAIN UNIT	CABLE TIES (8)	¼" TUBING	SPLIT PICK UP TUBE	SQUEEZE TUBE
2504	25-220-1	81-16-3	25-68-20 (LDPE)	81-312-1	81-231-1 (EPDM, JACO)
2505	25-220-1	81-16-3	25-160-20 (SUPER TUBE)	81-312-1	81-231-4 (EPDM, CONE)

Operational Requirements

For indoor use only	
Main Power	(8) D-CELL BATTERIES (NOT INCLUDED)
Case Material	ABS
Product Weight	1.18 kg 2.60 lbs.
The integrity and operational characteristics of this unit are not guaranteed outside the above mentioned parameters. Use of this unit outside of these parameters nullifies warranty.	

Overall Size

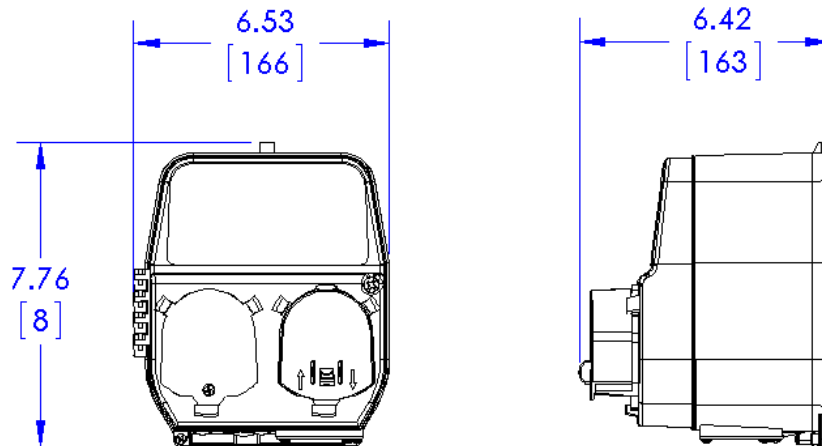

Parts List

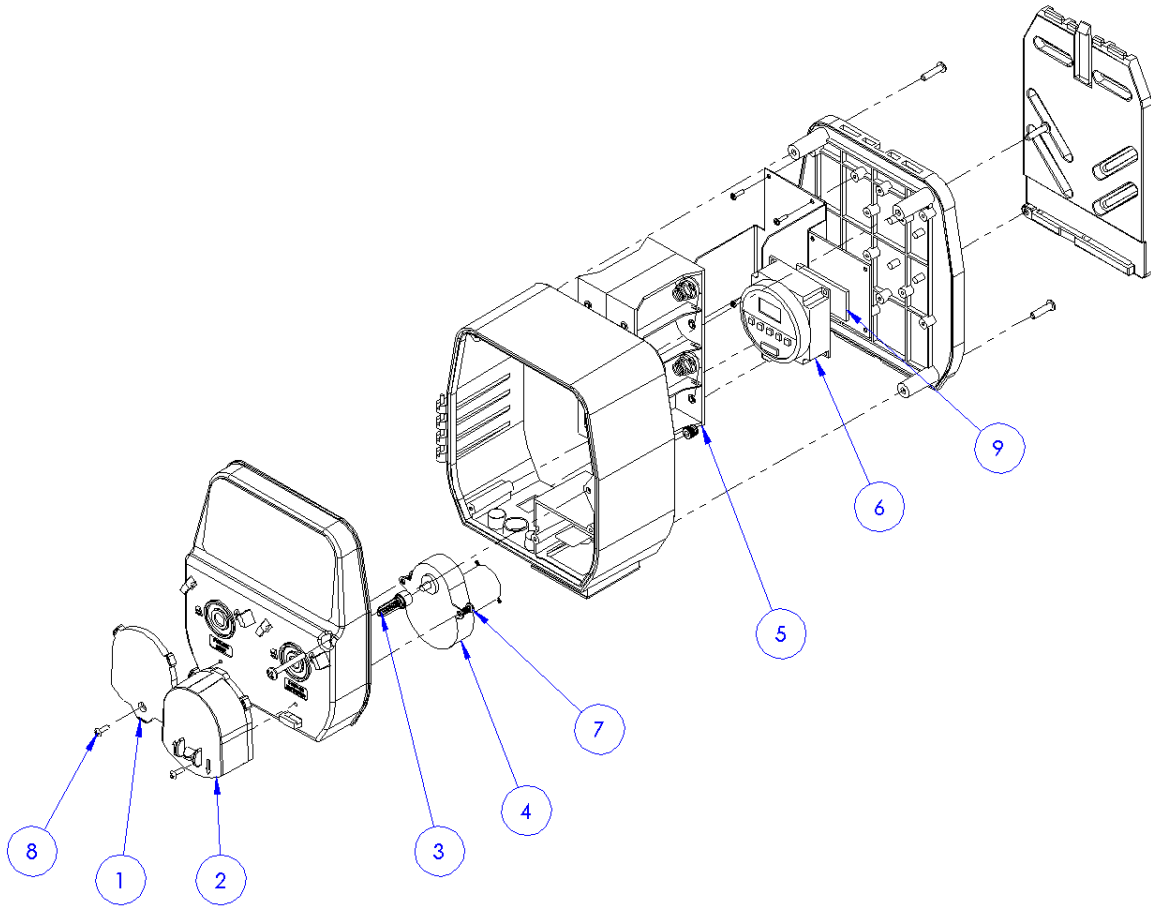

NO.	PART NO.	DESCRIPTION
1	81-278-1	PUMP BLANK COVER
2	81-226-5	PUMP HEAD ASSY.
3	81-220-1	DRIVE SHAFT ADAPTER
4	81-311-2	118 RPM MOTOR ASSEMBLY
5	25-212-2	(8) POSITION D-CELL BATTERY HOLDER
6	25-20-3	TIMER
7	44-116-2	#8 X 3/8" HI/LO SCREW
8	81-18-1	#6 X 3/8" HI/LO SCREW
9	83-16-2	VELCRO PATCH

Installation

Mount the unit no higher than 6 feet from the chemical container. Take into account the proximity to the chemical, and the drain. Secure the mounting bracket to the wall and then mount the unit on the wall. Cut the tubing to the proper length to reach from the chemical container to the dispenser and the dispenser to the drain where the chemical is being dispensed.

Squeeze Tube Installation

Install the squeeze tube by removing the pump cover by depressing the tab on the front of the unit. (1) Place one end of the squeeze tube on the left side of the pump in the slot provided. (2) Wrap the squeeze tube around the rollers of the pump. (3) Then stretch the squeeze tube so that the end of the tube goes into the slot provided. (4) Replace the cover on the pump.



(1)



(2)



(3)

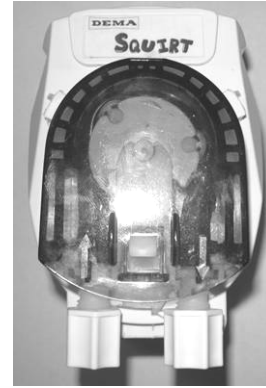

(4)

Close Pump Head

The pump head has an added feature which will help to ensure the pump head is retained properly. When pushing the pump head on, be sure to push the pump head on tightly so that the tab is grasping the pump head. If the tab is not fully engaged, there is a possibility the pump head becoming dislodged.

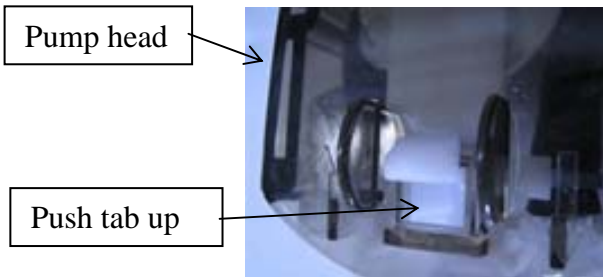

Correct



Incorrect

Operation

Programming the Dispenser

CAUTION: When the unit is powered the first time, a rechargeable display back up battery begins charging. When fully charged it provides approximately 200 hours of reserve time before the display and program may be lost. If the unit loses power, it will not lose the program for 200 hours, but it will not run the pump from the rechargeable display back up battery and will not dispense chemical. If the unit becomes unplugged from the wall for a short amount of time, plugging the unit back in will not affect the programming done to the unit.



A. Press the reset button before programming.

Note: If a mistake is made during the programming, simply push the reset button and start over.

B. 12 Hour or 24 Hour (Military) Mode

1. Hold the “Clock” button down for 5 seconds or more to change back & forth to between the 12 & 24 hour modes.

C. Set the Time and Day

When the unit arrives the display may be blank or may display a time. Insert the (8) D-Cell batteries into the dispenser and that will provide power to the timer.

NOTE: Make sure that the indicator bar in the bottom of the display is over the word OFF. Press the MANUAL button until it is in the off position.

1. To set the time and day of the week, press and hold the CLOCK button and press the day, hour, and minute buttons until the proper day, hour, and minute is achieved.

Note: The days will be across the top of the screen and will advance as the button is pressed. The time must be set to AM or PM. Pressing in the Day, Hour, or Minute button for three seconds will advance the setting until the button is released.

C. Programming the Dispensing Events: Up to 8 independent dispensing events can be programmed

1. Press and release the TIMER button to enter the programming mode. The event number will be in the bottom left corner. **Note: To program a full event, a pump start time and stop time will need to be programmed.**

NOTE: THE PUMP WILL RUN FOR 23 HRS 59 MIN NO SOP TIME HAS BEEN SET.

- a) Press the “DAY” button until the desired days are shown.
- b) Press the “HOUR” and “MINUTE” buttons until the time is reached when the pump should start.

Note: AM or PM in top left corner of screen.

2. Press and release the TIMER button again to move to programming the pump stop time.

- a) This setup will be used to turn the pump off. Use the table to determine the pump run time.
- b) Press the “DAY” button until the days match the days programmed in the pump start portion of the programming.
- c) Press the “HOUR” and “MINUTE” buttons until the desired run time is reached.

RUN TIME	AMOUNT DISPENSED	
	ml	oz
1 min	110 ml	3.5 oz
3 min	~295 ml	~10 oz
5 min	550 ml	17.5 oz
6 min	~590 ml	~20 oz
10 min	1100 ml	35 oz
20 min	2200 ml	70 oz

3. To program another event, press TIMER button again for Programs 2-8 and follow Programming Steps 1 and 2 above. Every START function needs a corresponding STOP function in order to stop the pump.
4. When finished programming, push the CLOCK button again to return to time of day (normal) display.

D. Priming the Pump

- To prime the pump, press the MANUAL button – the bar at the bottom of the display will move from right to left from OFF to AUTO to ON. When it reaches ON, the pump will run until the MANUAL button is pressed again. Use this position to prime the pump. To stop priming press the MANUAL button – the bar at the bottom of the display will move from left to right from ON to AUTO to OFF.

Note: The unit may continue to run in the AUTO position. The MANUAL button must be pressed until the bar at the bottom of the display is over the OFF position to stop the pump.

E. Setting into Programmed Position

- Press the MANUAL button until the bar in the bottom of the display moves from the OFF to the AUTO position. If the unit is not in the AUTO position, the program will not be executed.

Troubleshooting

Symptom	Probable Cause	Remedy
Pump running when it is not programmed to run.	<ol style="list-style-type: none"> The program, date, or time are set wrong. Did not program stop time. 	<ol style="list-style-type: none"> Check the program, date, and time to make sure they are set properly. A common mistake could be where an AM is supposed to be a PM. Check the programs for a stop time for each program.
Pump is not priming or not holding a prime.	<ol style="list-style-type: none"> Hole in the tubing from the chemical container to the pump head. Hole in the squeeze tube in the pump head. Pick up tubing is not sealed to the squeeze tube fitting. 	<ol style="list-style-type: none"> Check the tubing from the chemical container to the pump head for leaks by feeling the tubing for chemical that has leaked out. Replace the tube if necessary. Replace the squeeze tube after inspecting it for a possible hole or leak. Tighten the nuts on the squeeze tube fitting.
Pump over feeding (using too much chemical). Pump under feeding (not enough chemical).	<ol style="list-style-type: none"> The programs entered in the unit were set wrong. The batteries are low on power 	<ol style="list-style-type: none"> Check the program(s) to make sure they are set properly. A common mistake could be where an AM is supposed to be a PM. Replace batteries.
Pump runs constantly.	<ol style="list-style-type: none"> Did not match the Event #, Days or AM/PM for the stop time. 	<ol style="list-style-type: none"> Check the programs for a stop time for each program; make sure the events are matched up.

Warranty

Merchandise Returns

No Merchandise will be returned for credit without DEMA'S written permission. Returned merchandise authorization number is required in advance of return.

Product Warranty

DEMA products are warranted against defective material and workmanship under normal use and service for one year from the date of manufacture. This limited warranty does not apply to any products that have a normal life shorter than one year or failure and damage caused by chemicals, corrosion, physical abuse, or misapplication. Rubber and synthetic rubber parts such as "O"-rings, diaphragms, PVC tubing, and gaskets are considered expendable and are not covered under warranty. This warranty is extended only to

the original buyer of DEMA products. If products are altered or repaired without prior approval of DEMA, this warranty is void.

Defective units or parts should be returned to the factory with transportation prepaid. If inspection shows them to be defective, they will be repaired or replaced without charge, F.O.B. factory. DEMA assumes no liability for damages. Return merchandise authorization number must be granted in advance of returned units for repair or replacement (See "Merchandise Returns" above).