USER MANUAL

**MODEL NUMBER:
DS4
DS4K
DS4V
AND RELATED UNITS**

**Twin-Line Concentrate Doorway Foam
Unit**

English (Original Instructions)

READ ALL INSTRUCTIONS BEFORE OPERATING EQUIPMENT

WARNING



Read this manual completely and understand the machine before operating or servicing it.

- Read all instructions before installing or operating unit.
- Always wear appropriate personal protective equipment (PPE) when operating or servicing unit.
- Always follow all chemical safety precautions and handling instructions provided by the chemical manufacturer and Safety Data Sheet (SDS).
- If this unit is modified or serviced with parts not listed in this manual, the unit may not operate correctly.
- Do not exceed an incoming air pressure of 100 psi (7 bar).
- Do not exceed a fluid temperature of 100°F (37°C).
- Always flush the unit with fresh water for 5 minutes when switching from an alkaline to an acid or an acid to an alkaline.
- Never use unit with hydrocarbons or flammable products.
- Only use clean and dry air. Air must be filtered and free of moisture or pump life will be diminished. If needed, install an air dryer before unit.
- Do not use an air lubricator before the unit.
- Never use unit if it is damaged or leaking.
- Disconnect unit from electrical power source before servicing.

PROTECT THE ENVIRONMENT

Please dispose of packaging materials, old machine components, and hazardous fluids in an environmentally safe way according to local waste disposal regulations.



Always remember to recycle.

*Specifications and parts are subject to change without notice.

OPTIONS			
	Pump Seal Material		Number of Nozzles
DS4	Santoprene (<i>standard</i>)	-	One (<i>standard</i>)
	Viton (V)		Two (2)
	Kalrez (K)		Three (3)

Add bold option codes to item number as shown. For standard options, no option code is needed.

Examples:

- DS4 (standard unit with Santoprene pump seals and one nozzle)
- DS4-2 (unit with Santoprene pump seals and two nozzles)
- DS4V-2 (unit with Viton pump seals and two nozzles)

READ ALL INSTRUCTIONS BEFORE OPERATING EQUIPMENT

System Overview:

One control box can support up to three nozzle assemblies.

The combined distance between the control box and the nozzle(s) must equal 100 ft. (30.5 m) or less.

COMPLETE SYSTEMS			
Item Number:	DS4	DS4-2	DS4-3
Includes:	Control box and one nozzle assembly	Control box and two nozzle assemblies	Control box and three nozzle assemblies
Spray tip:	ST80200	ST80100	ST8060-1/2
Foam pattern:	Up to 9x5 ft. (2.7x1.5 m)	Up to 8x4 ft. (2.4x1.2 m) at each nozzle	Up to 6x3 ft. (1.8x0.9 m) at each nozzle
Tubing (H12CP) included:	50 ft. (15.2 m)	100 ft. (30.4 m)	150 ft. (45.7 m)
Tee fittings (QFT12) included:	0	2	4

REPLACEMENT NOZZLE ASSEMBLIES			
Item Number:	GK7T	GK7T-2	GK7T-3
Includes:	One nozzle assembly with ST80200 spray tip	One nozzle assembly with ST80100 spray tip, plus one extra ST80100 spray tip	One nozzle assembly with ST8060-1/2 spray tip
Intended use:	Replacement nozzle for a 1-nozzle system	Replacement nozzle for a 2-nozzle system, or conversion kit to turn an existing 1-nozzle system into a 2-nozzle system	Replacement nozzle for a 3-nozzle system
Spray tip:	ST80200	ST80100 (also includes an extra tip to retrofit an existing nozzle)	ST8060-1/2
Tubing (H12CP) included:	50 ft. (15.2 m)	50 ft. (15.2 m)	50 ft. (15.2 m)
Tee fittings (QFT12) included:	0	2	4

READ ALL INSTRUCTIONS BEFORE OPERATING EQUIPMENT

REQUIREMENTS	
Compressed air requirements	40-80 psi (3-5 bar) with 5-10 cfm (141.6-283.3 l/min)
Water requirements	10-100 psi (0.69-6.9 bar) Backflow prevention is required – consult local plumbing ordinances for more information.
Liquid temperature range	40-100°F (4.4-37°C)
Electrical requirements	120 VAC at 60 Hz, 2 amps (GFCI protected outlet)
Operating voltage	120 VAC
Chemical compatibility	Chemical products used with this equipment must be formulated for this type of application and compatible with unit materials and pump seals. For more information on chemical compatibility, consult the manufacturer or SDS for your product or contact our customer service department.

SPECIFICATIONS	
Power type	Compressed air, electricity
Chemical pickup type	Draws from concentrated product
Dilution ratio range (water:chemical)*	38:1 to 183:1
Number of products unit can draw from (and whether it draws simultaneously or one at a time)	One product
Suction line length/diameter	8 ft. (2.4 m) clear hose with 1/4 in. (6.4 mm) inside diameter
Flow rate*	2 gal/min (7.6 l/min)
Pump seals	Santoprene, Viton, or Kalrez
Timer operation type	Repeat cycle
Coverage area	With one nozzle: up to 9x5 ft. (2.7x1.5 m); With two nozzles: up to 8x4 ft. (2.4x1.2 m) at each nozzle; With three nozzles: up to 6x3 ft. (1.8x0.9 m) at each nozzle
Fan tip	With one nozzle: ST80200; With two nozzles: ST80100; With three nozzles: ST8060-1/2
Nozzle type	Twin-line stainless steel nozzle assembly (GK7T)
Number of nozzles	One control box can support up to three nozzle assemblies
Distance from nozzles to control box	The combined distance between the control box and the nozzle(s) must equal 100 ft. (30.5 m) or less.
Tubing/fitting sizes	Designed for use with 1/2 in. (12.7 mm) outside diameter tubing between control box and nozzle(s)

*Dilution rates and flow rates given are based on chemical with viscosity of water and factory air pressure settings.

READ ALL INSTRUCTIONS BEFORE OPERATING EQUIPMENT

Installation Instructions:

1. Remove all components from packaging.
2. Select an area to mount the control box.
Note: The control box should be mounted to a vertical wall. We recommend mounting the control box at a height of 6 feet or less. The chemical suction line must reach the bottom of the chemical container. The bottom of the chemical container should not be positioned higher than the bottom of the control box.
3. Attach the control box mounting feet to the back of the control box, using the four screws provided in the parts package.
4. Mount the control box to the wall using four of the screws and plastic anchors provided in the parts package.
Note: To drill holes for the plastic anchors, use a 5/16 inch drill bit.
5. Mount the stainless steel nozzle assembly in the desired location, using two stainless steel brackets (SSFTB) and four of the screws and plastic anchors provided in the parts package. Repeat as needed for multiple nozzles.
Note: The foam pattern dimensions provided in this manual were measured with nozzle assemblies mounted 6 in. (15 cm) above the floor.
6. Run tubing from the solution outlet fitting on the control box to the solution inlet fitting on the nozzle assembly. For multiple nozzles, run the tubing from the control box into a tee fitting (QFT12), as shown in the diagram. Then, run tubing from the tee fitting to the nozzle assemblies. For systems with three nozzles, use a second tee fitting to split the line again.
7. Run tubing from the air outlet fitting on the control box to the air inlet fitting on the nozzle assembly. For multiple nozzles, split the line using one or more tee fittings (QFT12), as described in step 6 and shown in the diagram.
Note: The air and solution lines must be routed to the appropriate fittings (as labeled), or the foam quality of the unit will be negatively impacted. Make sure to insert the tubing all the way into the fittings to ensure proper connection.

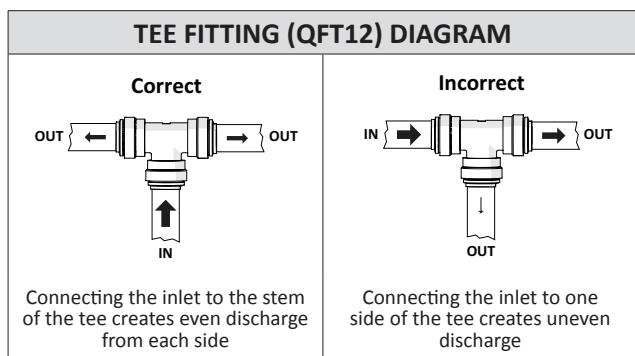

8. Connect the air inlet hose barb (HBSS1438) provided in the parts package to the air inlet valve (BVB14) located on the side of the control box. Then attach a 3/8 inch I.D. air line from your air compressor to the air inlet hose barb, and secure it with the smaller hose clamp provided in the parts package.
9. Connect a water line to the unit. The control box has a 1/2 inch FPT water inlet fitting (SSA12).
Note: A back-flow preventer must be installed in the water line – check local plumbing codes to ensure proper installation.
10. Open the cover of the control box. Insert the proper metering tip and connect the chemical intake line to the injector inlet barb.
Note: Use the included metering tip color chart to determine the appropriate metering tip based on the product and dilution rate you will be using.

INJECTION RATES		
METERING TIP COLOR	OZ./GAL.	RATIO*
TAN	0.70	183-1
ORANGE	0.90	142-1
TURQUOISE	1.15	111-1
PINK	1.55	83-1
LIGHT BLUE	1.80	71-1
BROWN	1.85	69-1
RED	2.65	48-1
WHITE	3.40	38-1

** Injection rates will vary based on chemical viscosity, air pressure, and many other factors. We recommend testing unit output to verify injection rate prior to use.

11. Place the other end of the chemical intake line into a chemical container.
Note: The chemical suction line must reach the bottom of the chemical container. A strainer must be used on the chemical intake line.
12. Set the timer for the desired on time and off time, as described in the timer adjustment instructions.

READ ALL INSTRUCTIONS BEFORE OPERATING EQUIPMENT

TIMER ADJUSTMENT INSTRUCTIONS

The TR120DS-A is an adjustable repeat cycle timer with the ON time operating first. ON and OFF times can range from 1 second to 511 minutes.

To set the timer:

1. Starting with the ON time, move the top dip switch to the left for SEC (seconds) or to the right for MIN (minutes) to select the desired time interval.
2. The next 9 dip switches will be used to control the total active time. To the left is inactive and to the right is active. Combine the numbers next to the active dip switches to achieve the desired time.
3. Repeat the above steps for the OFF time setting.

Operation Instructions:

1. Verify that the unit is connected to compressed air, water, power, and chemical.
2. Open the compressed air inlet valve (BVB14).
3. To activate the unit, turn the power switch ON. The unit will begin cycling through the on time and off time intervals set on the timer, beginning with the on time.
4. While the unit is running and discharging product, adjust the needle valve (NV14Y), located inside the control box, as needed to regulate the wetness or dryness of the foam following the steps below:
 - a. Close needle valve (NV14Y) completely in clockwise direction.
 - b. Open needle valve (NV14Y) in counter-clockwise direction 2 complete turns.
 - c. Continue to open needle valve in ¼ turn increments, allowing 30 seconds between adjustments, until desired consistency of foam is achieved.
5. To deactivate the unit, turn the power switch OFF.

13. With the power switch in the OFF position, plug the unit into a GFCI protected 120 VAC power outlet.

READ ALL INSTRUCTIONS BEFORE OPERATING EQUIPMENT

Maintenance Instructions:

To keep your foam unit operating properly, periodically perform the following maintenance procedures:

Note: Before performing any maintenance, ensure that the unit has been turned OFF, unplugged from the electrical power source, and disconnected from the air/water supply.

- Inspect the pump (P56/P56K/P56V) for wear and leaks.
- Inspect all hoses for leaks or excessive wear. Make sure all hose clamps and push-fittings are in good condition and properly secured.
- Replace the filter (AFR25) located within the air regulator (R25) as needed. Clean by unthreading the air regulator bowl (ABR25) from the air regulator (R25).
- Check the chemical metering tip, suction line and strainer for debris and clean as needed.
- Drain your air compressor tank on a regular basis to help extend pump life. An air source with a high moisture content will accelerate pump wear. Note: If your air source has a high moisture content, you may wish to install a water separator (item number WS-20CFM, sold separately) before the unit.

Troubleshooting Instructions:

- Check the air regulator bowl (ABR25) and air filter (AFR25) for debris such as water, oil, or rust particles. Clean by unthreading the air regulator bowl (ABR25) from the air regulator (R25).
- If the needle valve (NV14Y) is open too far, the pump (P56/P56K/P56V) may cycle improperly due to lack of air pressure. If this occurs, close and readjust the needle valve (NV14Y) as described in Operation Instruction #2.
- Make sure proper foaming chemical and concentration are being used.
- If air passes through the pump (P56/P56K/P56V) without cycling, the pump needs to be replaced.
- If solution backs up into the air regulator bowl (ABR25), the check valve (CV38) needs to be replaced.
- If foam comes out wet, no matter where the needle valve (NV14Y) is positioned, the check valve (CV38) may need to be replaced.
- Check for proper air pressure on the air gauge (AG100). The air regulator (R25) is factory set at 50 psi (3.4 bar). Operating range is 40 to 80 psi (3 to 5 bar) with 3.5 to 8 CFM (99 to 226.5 l/min).
- If the unit operates at a reduced pressure:
 - o Check the air compressor supplying the unit. If the pressure is less than 40 psi, turn the unit off until the compressor can catch up.
 - o If the air supply is 50 psi (3.4 bar) or above, check the air gauge (AG100), which should read near 50 psi (3.4 bar). If the air gauge reads more or less than 50 psi (3.4 bar), adjust the pressure by turning the knob on the top of the air regulator (R25).
- Check the chemical metering tip, suction line and strainer for debris or damage. Clean or replace as needed. To prevent damage to the unit, the strainer must always be used.
- Check for proper water pressure on the water pressure gauge (WRG14). To check the pressure:
 - o Activate the unit and allow it to run through an on time cycle.
 - o During the subsequent off time cycle, check the water pressure gauge (WRG14). The pressure should read 30 psi (2.1 bar) during the off time cycle or when deadheaded.
 - o If necessary, adjust the water regulator using the flathead screw on the regulator body. The water pressure should be set at 30 psi (2.1 bar) when deadheaded. Setting the pressure higher or lower may damage the unit or cause it to malfunction.

READ ALL INSTRUCTIONS BEFORE OPERATING EQUIPMENT

CONTROL BOX ASSEMBLY

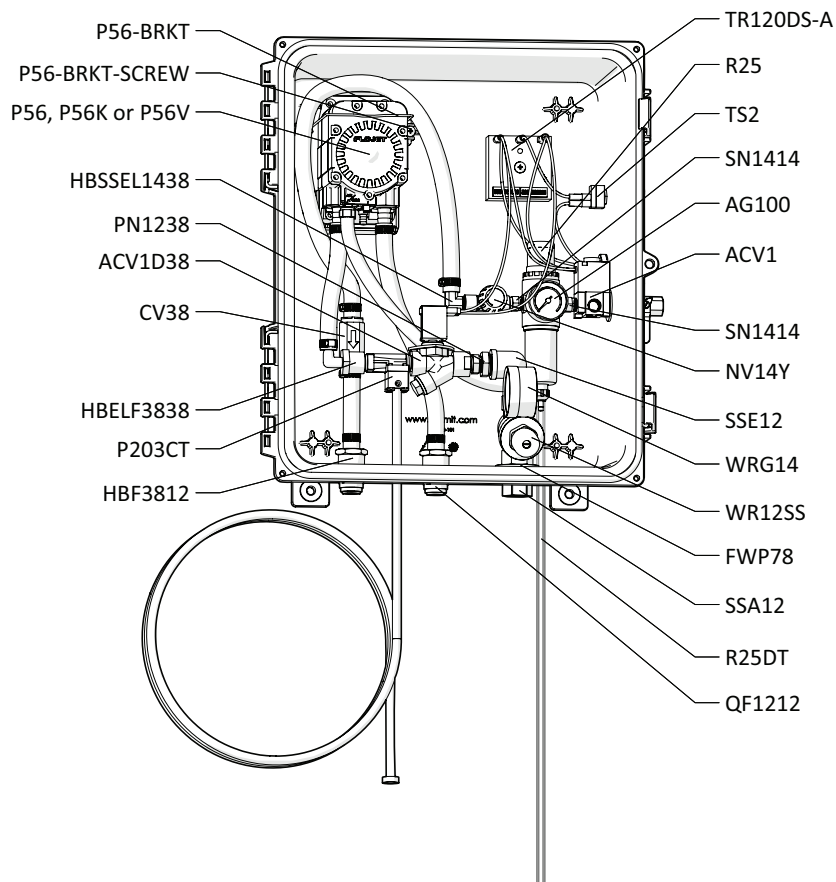
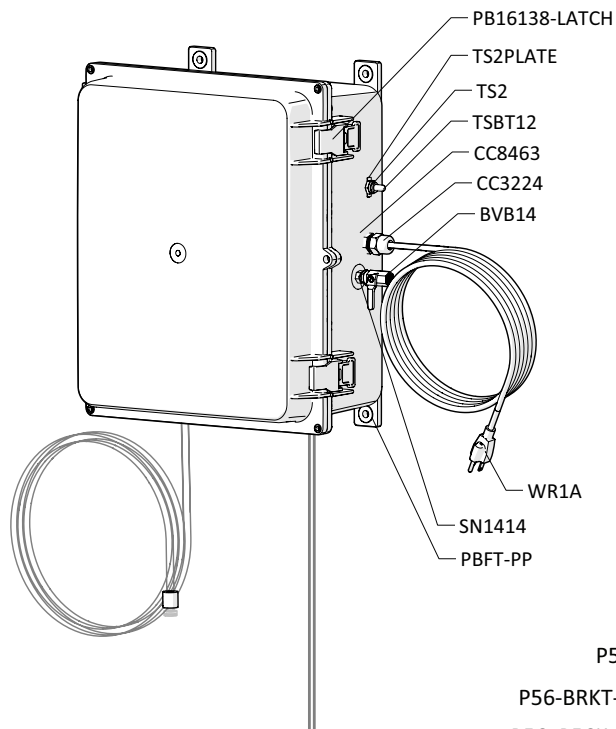

READ ALL INSTRUCTIONS BEFORE OPERATING EQUIPMENT

NOZZLE ASSEMBLY

QF1212
CV12F7-AP
SN1212
SSE12
QF1212
SST12
SN1212
HHSB11412
SSFT
HHSB11412
SSE12
ST80200, ST80100 or ST8060-1/2
(Spray tip size varies based on number of nozzle assemblies used - see specifications chart for more information.)

NOZZLE ASSEMBLY DETAIL
This unit includes an adjustable ball-type nozzle that may be installed to hold the spray tip as shown.

ABTN12
ABTNTB12

PARTS INFORMATION - LEGACY/DISCONTINUED COMPONENTS

LEGACY WATER REGULATOR ASSEMBLY
LEGACY PARTS DIAGRAM

PN3834
PEL34F
WR15G34
HHSB34GH12
SSA12

LEGACY PARTS LIST

ITEM NUMBER	DESCRIPTION
HHSB34GH12	STAINLESS HEX HEAD BUSHING 3/4in MGH BY 1/2 FPT
PEL34F	3/4in FEMALE POLY PIPE ELBOW 90
PN3834	POLY REDUCER NIPPLE 3/8in MPT X 3/4in MPT
WR15G34	WATER PRESSURE REGULATOR - 3/4in FGH BY 3/4in MPT Body ABS, internal parts, SS, PP and Santo

Conversion kit to upgrade to current water inlet: CK-WR12SS.

READ ALL INSTRUCTIONS BEFORE OPERATING EQUIPMENT

ITEM NUMBER	DESCRIPTION
ABTN12	ADJUSTABLE BALL-TYPE NOZZLE 1/2in NPT
ABTNTB12	1/2in THREADED BALL FOR ABTN12
ACV1	MAC VALVE 1/4in 110VAC
ACV1D38	110VAC SOLENOID VALVE 3/8in
AG100	1.5 INCH DRY MODEL 20 DUAL SCALE GAUGE
B10321	10-32 X 1 PHIL TRUSS MACH SCR 18-8
B10321.25	10-32 X 1 1/4 PHIL TRUSS MACH 18-8
BVB14	AIR INLET VALVE - VA BRS 025-4F4F-BT, NICKEL
CC3224	LTC BLACK 1/2 NPT
CC8463	1/2in NPT BLACK LOCKNUT
CV12F7-AP	1/2 CHECK VALVE 7 LB SPRING - HASTELLOY SPRING - EP SEALS - ACID PROOF - BLK/WHT CHK
CV38	PVC CHECK VALVE 3/8 BARBS - SS SPRING
EC14-2	OETIKER CLAMP 13.8
FWLG14	.569 ID X 1.28 OD X .08 THICK FLAT WASHER SS 18-8
FWP12	7/8 ID X 1.5 OD X 0.05 THK SSFW
FWP78	7/8in BY .137 BY 1 1/4in FLATWASHER 18-8 PLN
H12CP	1/2IN OD POLYETHYLENE TUBING - NATURAL - Available per ft.
H14B-H	1/4 INCH BLUE HOSE - Available per ft.
H38B-H	3/8 INCH BLUE HOSE - Available per ft.
HBELF3838	HOSE BARB ELBOW 3/8" BY FPT 3/8"
HBF3812	HOSE BARB 3/8 X FEMALE PIPE THREAD 1/2 IN
HBSS1438	STAINLESS HOSE BARB 1/4 MPT X 3/8 BARB
HBSEL1438	STAINLESS HOSE BARB ELBOW 1/4 NPT X 3/8 HOSE BARB
HBSEL1814	304 STAINLESS ELBOW 1/8 INCH NPT X 1/4 INCH HOSE BARB
HHSB11412	HEX HEAD STAINLESS BUSHING 1 1/4IN BY 12IN
NV14Y	FLOW CONTROL VALVE - INCLUDES BLACK KNOB
<i>NV14Y-HNDL</i>	BLACK KNOB FOR NEEDLE VALVE - 2839-1/4
P203CT	PLASTIC INJECTOR KIT INCLUDES INJECTOR - INTAKE HOSE - FOOT STRAINER AND WEIGHT - TIP KIT
P56	5700 PUMP WITH SANTOPRENE SEALS - INCLUDES HOSE BARBS, AIR FITTING, AND AIR PORT
P56K	5700 PUMP WITH KALREZ SEALS - INCLUDES HOSE BARBS, AIR FITTING, AND AIR PORT
P56V	5700 PUMP WITH VITON SEALS - INCLUDES HOSE BARBS, AIR FITTING, AND AIR PORT
<i>20756103B</i>	Polypro G57 Air Port x HB Straight, w/ Viton o-ring
<i>HB14P</i>	1/4in BRASS HB AIR FITTING /G57/P56
<i>HB5638</i>	HOSE BARB FOR P56 PUMP
<i>HB5638K</i>	HOSE BARB FOR P56K PUMP
<i>HB5638V</i>	HOSE BARB FOR P56V PUMP
P56-BRKT	PUMP BRACKET- STAINLESS STEEL
P56-BRKT-SCREW	HI LO SCREW FOR RETAINING P56-BRKT

PB16138	POLYPROPYLENE CONTROL BOX - WORKING DIMS 16x13x8 - PUMP MOUNT
PB16138-GSKT	NEOPRENE GASKET 0.220 INCH ROUND CORD STOCK - 61.125 INCHES
PB16138-LATCH	LATCH FOR PB16138
PB16138-PIN	STAINLESS STEEL HINGE PIN FOR CONTROL BOX PB16138
PBFT-PP	MOUNTING FEET FOR POLYBOX - PB16138 - POLYPROPYLENE
PL16138	POLYPROPYLENE - 16x13x8 - HINGED LOCKABLE LID
PN1238	1/2in MPT X 3/8 in MPT POLY NIPPLE
QF1212	MALE CON. 1/2in TUBE X 1/2in MPT - POLYPROPYLENE
QFT12	UNION TEE 1/2in TUBE - POLYPROPYLENE
R25	AIR REGULATOR - 1/4ft TWO PORT 1/8ft TWO PORT - INCLUDES FILTER AND BOWL
<i>AFR25</i>	AIR FILTER for R25
<i>ABR25</i>	METAL AIR BOWL for R25
R25DT	CLEAR TUBING FOR R25 DRAIN
S1034FHL	10 X 3/4 PHIL FLAT HI-LO THRD SCREW 18-8
SN1212	1/2in HEX STAINLESS STEEL NIPPLE
SN1414	STAINLESS 1/4MPT X 1/4MPT NIPPLE
SSA12	STAINLESS MALE/FEMALE S.S. ADAPTOR 1/2in X 1/2in
SSC38	WORM GEAR CLAMP, S/S (.25-.63)
SSE12	STREET ELBOW 1/2in - 316 S.S.
SSFT	Stainless Steel Foam Tube 1 1/2in @ 8INCH CUT
SSFTB	STAINLESS STEEL FOAM TUBE BRACKET
SSMESH	STAINLESS STEEL MESH
SSST	SCREEN DISC .687 DIA. 10 X 10 MESH @ .020 DIA
SST12	1/2in FPT 304 S.S. TEE
ST80100	VEEJET NOZZLE, 80100
ST80200	VEEJET NOZZLE, 80200
ST8060-1/2	1/2 INCH VEEJET NOZZLE, BRASS 8060
TR120DS-A	REPEAT CYCLE TIMER - ADJUSTABLE DIGI-SET - 120 VAC
TS2	TOGGLE SWITCH SPST
TS2PLATE	ON/OFF SWITCH PLATE
TSBT12	TOGGLE SWITCH BOOT
WCB14F	14-16 - 1/4 FEM INSULATED CONNECTOR
WCB14FY	10-12 - 1/4in FEMALE INSULATED CONNECTOR
WMS14	14 X 1 1/4 HEX W/H SMS SLOTT, S/S
WMS14A	5/16 X 1 1/2 STRAIGHT PLASTIC ANCHOR
WR12SS	WATER PRESSURE REGULATOR - STAINLESS STEEL - 1/2 INCH FPT
WR1A	18/3 SJOOW 90 BLACK N.A. W/ 5-15P & 7in ROJ
WRG14	WATER PRESSURE REGULATOR GAUGE FOR WR12SS